

# Improving fuzzy logic controllers obtained by experts: a case study in HVAC systems

Rafael Alcalá · Jesús Alcalá-Fdez · María José Gacto · Francisco Herrera

Published online: 28 December 2007  
© Springer Science+Business Media, LLC 2007

**Abstract** One important Artificial Intelligence tool for automatic control is the use of fuzzy logic controllers, which are fuzzy rule-based systems comprising expert knowledge in form of linguistic rules. These rules are usually constructed by an expert in the field of interest who can link the facts with the conclusions. However, this way to work sometimes fails to obtain an optimal behaviour. To solve this problem, within the framework of Machine Learning, some Artificial Intelligence techniques could be successfully applied to enhance the controller behaviour.

Rule selection methods directly obtain a subset of rules from a given fuzzy rule set, removing inefficient and redundant rules and, thereby, enhancing the controller interpretability, robustness, flexibility and control capability. Besides, different parameter optimization techniques could be applied to improve the system accuracy by inducing a better cooperation among the rules composing the final rule base.

This work presents a study of how two new tuning approaches can be applied to improve FLCs obtained from the expert's experience in non trivial problems. Additionally, we analyze the positive synergy between rule selection and tuning techniques as a way to enhance the capability of these methods to obtain more accurate and compact FLCs. Finally,

in order to show the good performance of these approaches, we solve a real-world problem for the control of a heating, ventilating and air conditioning system.

**Keywords** HVAC systems · Fuzzy logic controllers · Genetic tuning · Linguistic 2-tuples representation · Linguistic 3-tuples representation · Rule selection

## 1 Introduction

One important Artificial Intelligence tool for automatic control is the use of Fuzzy Logic Controllers (FLCs). FLCs are Fuzzy Rule-Based Systems (FRBSs) comprising expert knowledge in form of linguistic rules. Frequently, these rules are constructed by experts in the field of interest who can link the facts or evidence with the conclusions. In case of simple problems, an expert should have no problems in obtaining appropriate rules presenting a good cooperation. However, in the case of real complex problems with many variables and rules, this way to work fails to obtain an optimal performance as it is very difficult for human beings to ensure a good cooperation among rules.

To solve this problem, within the framework of Machine Learning, some Artificial Intelligence techniques could be successfully applied to enhance the controller performance. One of the most widely-used approaches for improving the performance of FRBSs, known as *tuning*, consists of refining a previous definition of the Data Base (DB) once the Rule Base (RB) has been obtained [1, 7, 11, 17, 23, 24] (in our case by experts). Classically, the tuning methods refine the three definition parameters that identify triangular Membership Functions (MFs) associated to the labels comprising

---

R. Alcalá (✉) · J. Alcalá-Fdez · M.J. Gacto · F. Herrera  
Department of Computer Science and Artificial Intelligence,  
University of Granada, 18071 Granada, Spain  
e-mail: [alcala@decsai.ugr.es](mailto:alcala@decsai.ugr.es)

J. Alcalá-Fdez  
e-mail: [jalcala@decsai.ugr.es](mailto:jalcala@decsai.ugr.es)

M.J. Gacto  
e-mail: [mjgacto@ugr.es](mailto:mjgacto@ugr.es)

F. Herrera  
e-mail: [herrera@decsai.ugr.es](mailto:herrera@decsai.ugr.es)

the DB [11, 12] in order to find its best global configuration (to induce to the best cooperation among the rules). However, in the case of problems with many variables, the dependency among MFs and the dependency among the three definition points, leads to tuning models handling very complex search spaces which affect the good performance of the optimization methods [4].

Recently, two new linguistic rule representation models have been proposed in order to face this particular problem [4, 5]:

- The first one was proposed to perform a genetic lateral tuning of MFs [4]. This new approach is based on the linguistic 2-tuples representation [16] that allows the symbolic translation of a label by only considering one parameter per label and therefore involves a reduction of the search space that eases the derivation of optimal models with respect to the classic tuning.
- The second one was presented to perform a fine genetic Lateral and Amplitude tuning (LA-tuning) of MFs [5]. This is based on the linguistic 3-tuples approach [5] by proposing a new symbolic representation with three values  $(s, \alpha, \beta)$ , respectively representing a label, the lateral displacement and the amplitude variation of the support of this label. Tuning of both parameters also involves a reduction of the search space that eases the derivation of optimal models with respect to the classic tuning.

In addition, rule selection methods directly obtain a subset of rules from a given fuzzy rule set, removing inefficient and redundant rules and, thereby, enhancing the controller interpretability, robustness, flexibility and control capability [10, 21, 22, 25, 26]. In this way, the combination of tuning techniques with rule selection methods can present a positive synergy, reducing the tuning search space, easing the system readability and even improving the system accuracy.

In this work, we present a study of how these new tuning approaches can be applied to improve FLCs obtained from the expert's experience in non trivial problems. Additionally, we analyze the positive synergy between rule selection and tuning techniques as a way to enhance the capability of these methods to obtain more accurate and compact FLCs. To show the good performance of these approaches we solve a real-world problem in the control of a Heating, Ventilating and Air Conditioning (HVAC) system [1], in which the initial FLC is obtained by experts.

This paper is arranged as follows. The next section presents the lateral tuning, the linguistic rule representation model (based on the linguistic 2-tuples) and details the evolutionary method proposed to perform the lateral tuning of FLCs. Section 3 presents the LA-tuning, the linguistic rule representation model (based on the linguistic 3-tuples)

and describes the evolutionary algorithm to perform the LA-tuning. In Sect. 4, the cooperation between each tuning approach and a rule selection mechanism is analysed, presenting the evolutionary methods to perform them together. Section 5 presents a case study in a HVAC system control problem, establishing the objective function and describing the initial FLC variables and structure. Section 6 shows an experimental study of the methods behaviour applied to that problem. Finally, Sect. 7 points out some conclusions.

## 2 Lateral tuning of fuzzy logic controllers

This section introduces the lateral tuning of fuzzy systems, presenting the new structure of fuzzy rule and a global semantics-based tuning approach. Next, an evolutionary post-processing method to perform lateral tuning of FLCs obtained by experts is described. This method is based on that proposed in [4] for the global lateral tuning of FRBSs.

### 2.1 Linguistic 2-tuples re-presented rule and lateral tuning

In [4], a new model of tuning of FRBSs was proposed considering the linguistic 2-tuples representation scheme introduced in [16], that allows the lateral displacement of the support of a label maintaining the interpretability associated with the final linguistic model at a reasonable level. This new tuning approach was based on a simple data-driven learning method and a Genetic Algorithm (GA) guided by example data and considering a generational approach.

In [16], the lateral displacement represented by a linguistic 2-tuple is named symbolic translation of a linguistic label. The symbolic translation of a label is a number within the interval  $[-0.5, 0.5)$ , expressing this interval the domain of a label when it is moving between its two adjacent lateral labels (see Fig. 1a). Let us consider a set of labels  $S$  representing a fuzzy partition. Formally, to represent the symbolic translation of a label in  $S$  we have the 2-tuple,

$$(s_i, \alpha_i), \quad s_i \in S, \quad \alpha_i \in [-0.5, 0.5).$$

In fact, the symbolic translation of a label involves the lateral displacement of its associated MF. As an example, Fig. 1 shows the symbolic translation of a label represented by the pair  $(s_2, -0.3)$  together with the lateral displacement of the corresponding MF. Both the linguistic 2-tuples representation model and the elements needed for linguistic information comparison and aggregation, are presented and applied to the Decision Making framework in [16].

In the context of FRBSs, the linguistic 2-tuples could be used to represent the MFs comprising the linguistic rules. This way to work, introduces a new model for rule representation that allows the tuning of the MFs by learning their

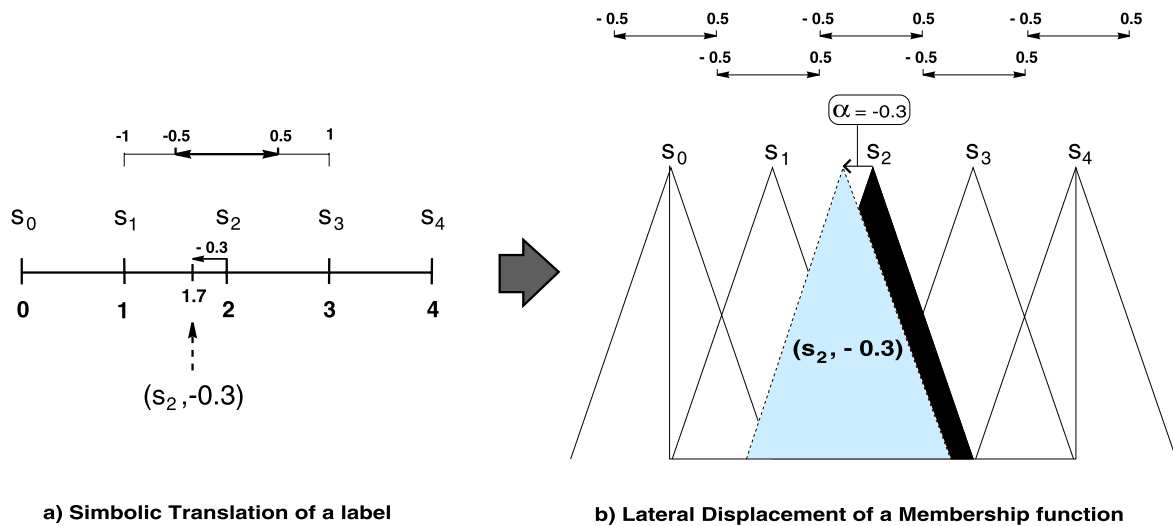

**Fig. 1** Symbolic translation of a linguistic label and lateral displacement of the involved MF

respective lateral displacements. Next, we present this approach by considering a simple control problem.

Let us consider a control problem with two input variables ( $X_1, X_2$ ), one output variable ( $Y$ ) and an initial DB defined by experts to determine the MFs for the following labels:

- $X_1$ :  $Error \rightarrow \{Negative, Zero, Positive\}$ ,
- $X_2$ :  $\nabla Error \rightarrow \{Negative, Zero, Positive\}$ ,
- $Y$ :  $Power \rightarrow \{Low, Medium, High\}$ .

Based on this DB definition, examples of classic and linguistic 2-tuples represented rules are:

– *Classic Rule,*

$R_i$ : If the **error** is Zero and the  $\nabla$ **Error** is Positive  
Then the **Power** is High.

– *Rule with 2-Tuples Representation,*

$R_i$ : If the **error** is (Zero, 0.3) and the  $\nabla$ **Error** is (Positive,  $-0.2$ ) Then the **Power** is (High,  $-0.1$ ).

Analysed from point of view of rule interpretability, we could interpret the 2-tuples represented rule (i.e., a tuned rule) as:

If the **Error** is “higher than Zero” and  
the  $\nabla$ **Error** is “a little smaller than Positive”.  
Then the **Power** is “a bit smaller than High”.

In [4], two different rule representation approaches were proposed, a global approach and a local approach. In our particular case, the learning is applied to the level of linguistic partitions (global approach). In this way, the pair ( $X_i$ ,

label) takes the same  $\alpha$  value in all the rules where it is considered. For example,  $X_i$  is (High, 0.3) will present the same value for those rules in which the pair “ $X_i$  is High” was initially considered. That is to say, only one displacement parameter is considered for each label on the DB.

The main difference between lateral tuning and the classic approach is the reduction of the search space focusing the search only on the MF support position, since the 3 parameters usually considered per label are reduced to only 1 symbolic translation parameter. Although lateral tuning has less freedom than the classic approach, the reduction of the search space could lead to improved performance of the tuning method, especially in complex or highly multidimensional problems, since this allows us to obtain easily the best global interaction between the MFs, thereby ensuring a good covering degree of the input data. Other important aspect is that, from the parameters  $\alpha$  applied to each label, we could obtain the equivalent triangular MFs, by which a FRBS based on linguistic 2-tuples could be represented as a classic Mamdani FRBS [28, 29].

In this work, the fuzzy reasoning method considered is the *minimum t-norm* playing the role of implication and conjunctive operators, and the *centre of gravity weighted by the matching* strategy acts as defuzzification operator. These kinds of inference are applied once the 2-tuples represented model is transformed to (represented by) its equivalent classic Mamdani FRBS.

### 2.2 Algorithm for the lateral tuning

To perform the lateral tuning of MFs, in these kinds of complex problems, we consider a GA based on the well-known steady-state approach. The steady-state approach [35] consists of selecting two of the best individuals in the population

and combining them to obtain two offspring. These two new individuals are included in the population replacing the two worst individuals if they are better adapted. An advantage of this technique is that good solutions are used as soon as they are available. Therefore, the convergence is accelerated while the number of evaluations needed is decreased.

In the following, the components needed to design this process are explained. They are: coding scheme and initial gene pool, chromosome evaluation, genetic operators and a restarting approach to avoid premature convergence.

- *Coding Scheme*—For the  $C_T$  part, a real coding is considered, i.e., the real parameters are the GA representation units (genes). This part is the joining of the  $\alpha$  parameters of each fuzzy partition. Let us consider the following number of labels per variable:

$$(m^1, m^2, \dots, m^n),$$

with  $n$  being the number of system variables. Then, a chromosome has the form (where each gene is associated to the lateral displacement of the corresponding label in the DB),

$$C_T = (c_{11}, \dots, c_{1m^1}, c_{21}, \dots, c_{2m^2}, \dots, c_{n1}, \dots, c_{nm^n}).$$

See the  $C_T$  part of Fig. 5 (in Sect. 4) for a graphical example of coding scheme considering this approach.

- *Initial Gene Pool*—To make use of the available information, the initial FRBS obtained from expert knowledge is included in the population as an initial solution. To do so, the initial pool is obtained with the first individual having all genes with value ‘0.0’, and the remaining individuals generated at random in  $[-0.5, 0.5)$ .
- *Evaluating the Chromosome*—The fitness function depends on the problem being solved (see Sect. 5.1 for our particular case of study).
- *Genetic Operators*—In part, the crossover operator is based on the concept of environments (the offspring are generated in an interval generated around their parents). These kinds of operators present good cooperation when they are introduced within evolutionary models forcing the convergence by pressure on the offspring (as in the case of the steady-state approach). Particularly, we consider a BLX- $\alpha$  crossover [14] and a hybrid between a BLX- $\alpha$  and an arithmetic crossover [18] (Fig. 2 shows the performance of these kinds of operators, which allows the offspring genes to be around a wide zone determined by both parent genes). In this way, the crossover operator is described as follows. Let us assume that  $X = (x_1, \dots, x_g)$  and  $Y = (y_1, \dots, y_g)$ , ( $x_i, y_i \in [a_i, b_i] \subset \mathfrak{R}, i = 1, \dots, g$ ), are two real-coded chromosomes that are going to be crossed:

1. Using the BLX- $\alpha$  crossover [14] (with  $\alpha = 0.3$ ), one descendent  $Z = (z_1, \dots, z_g)$  is obtained, where

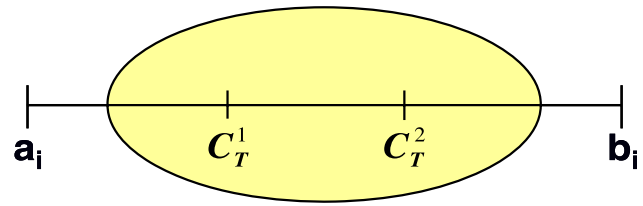

**Fig. 2** Diagram of performance of the crossover operators based on environments

$z_i$  is randomly (uniformly) generated within the interval  $[l_i, u_i]$ , with  $l_i = \max\{a_i, c_{min} - I\}$ ,  $u_i = \min\{b_i, c_{max} + I\}$ ,  $c_{min} = \min\{x_i, y_i\}$ ,  $c_{max} = \max\{x_i, y_i\}$  and  $I = (c_{max} - c_{min}) \cdot \alpha$ .

2. The application of an arithmetic crossover [18] in the wider interval considered by the BLX- $\alpha$ ,  $[l_i, u_i]$ , results in the next descendent:

$$V \quad \text{with } v_i = a \cdot l_i + (1 - a) \cdot u_i,$$

where  $a_i$  and  $b_i$  are respectively  $-0.5$  and  $0.5$ , and  $a \in [0, 1]$  is a random parameter generated each time this crossover operator is applied. In this way, this operator performs the same gradual adaptation in each gene, which involves a faster convergence in the algorithm.

Besides, no mutation will be considered in order to favour the exploitation with respect to the exploration. For this reason, we also consider a restarting approach to avoid local optima.

- *Restarting Approach*—To get away from local optima, this algorithm uses a restart approach [13]. In this case, the best chromosome is maintained and the remaining are generated at random within the corresponding variation intervals  $[-0.5, 0.5)$ . It follows the principles of CHC [13], performing the restart procedure when the difference between the worst and the best chromosome fitness values is less than 1% of the initial solution fitness value. This way to work allows the algorithm to perform a better exploration of the search space and to avoid getting stuck at local optima.

Finally, the main steps of the algorithm can be found in Fig. 3 by taking into account the described components.

### 3 The LA-tuning of fuzzy logic controllers

This section introduces the lateral and amplitude tuning of fuzzy systems, presenting the new structure of fuzzy rule and a global semantics-based tuning approach. Then, the evolutionary post-processing method to perform LA-tuning of FLCs obtained by experts is described. This method is based on that proposed in [5] for the global LA-tuning of FRBSs.

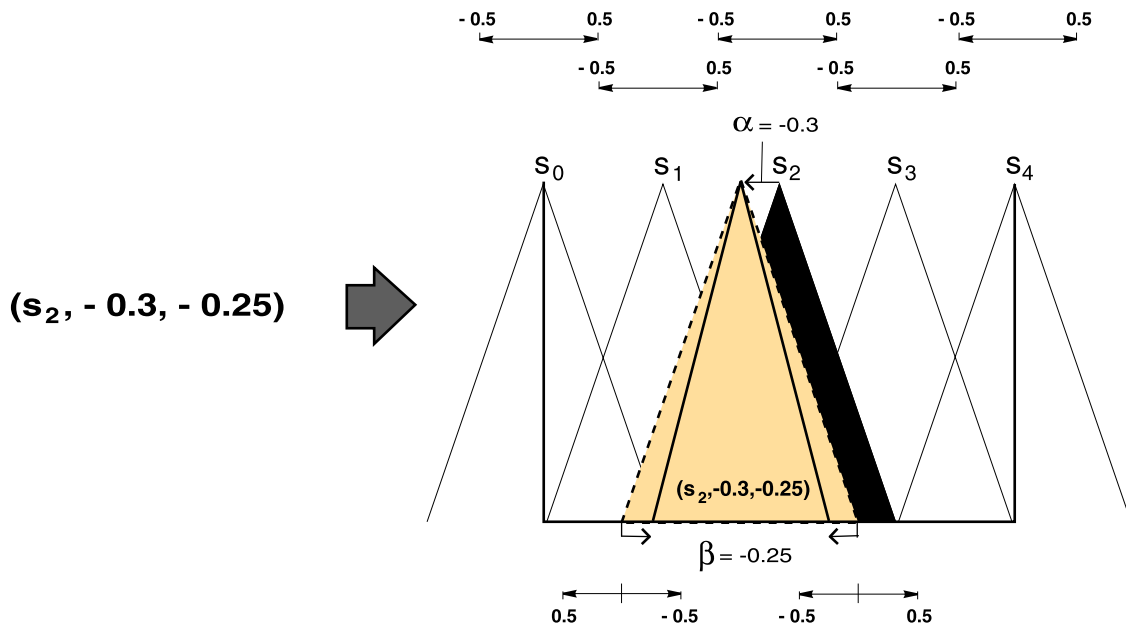

Fig. 4 Lateral and amplitude variation of the MF associated to  $s_2$

1. Generate the initial population with  $N$  chromosomes.
2. Evaluate the population. Let  $F_{ini}$  be the fitness of the initial solution obtained by experts.
3. Perform a probabilistic selection of two of the best individuals in the population.
4. Cross these individuals to obtain two offspring (hybrid BLX- $\alpha$ /arithmetic).
5. Evaluate the two offspring.
6. Replace the two worst individuals in the population by the two new individuals if they are better adapted. Let  $F_{best}$  and  $F_{worst}$  be the best and the worst chromosome fitness values.
7. If  $(F_{worst} - F_{best} < 0.01 * F_{ini})$ , restart the entire population with the best.
8. If the maximum number of evaluations is not reached, go to Step 3.

Fig. 3 Scheme of the algorithm

### 3.1 Linguistic 3-tuples re-presented rule and LA-tuning

The LA-tuning [5] is an extension of the lateral tuning to perform also a tuning of the support amplitude of the MFs. This new approach was also based on a simple data-driven learning method and a GA guided by example data and considering a generational approach.

Determining the amplitude of a MF is a way to decide which examples are covered or not, better grouping a set of data. Therefore, tuning the amplitude of the MFs can help,

- To decrease the number of negative examples (those covered in the antecedents but not in the consequents),
- To increase the number of positive examples (those covered in the antecedents and also in the consequents), or

- To reduce the number of rules if a rule selection method is considered.

To adjust the displacements and amplitudes of the MF supports we propose a new rule representation model that considers two parameters,  $\alpha$  and  $\beta$ , relatively representing the lateral displacement and the amplitude variation of a label. In this way, each label can be represented by a 3-tuple  $(s, \alpha, \beta)$ , where  $\alpha$  is a number within the interval  $[-0.5, 0.5)$  that expresses the domain of a label when it is moving between its two adjacent lateral labels (as in the 2-tuples representation), and  $\beta$  is also a number within the interval  $[-0.5, 0.5)$  that allows to increase or reduce the support amplitude of a label until 50% of its original size. Let us consider a set of labels  $S$  representing a fuzzy partition. Formally, we have the triplet,

$$(s_i, \alpha_i, \beta_i), \quad s_i \in S, \{\alpha_i, \beta_i\} \in [-0.5, 0.5).$$

As an example, Fig. 4 shows the 3-tuple represented label  $(s_2, -0.3, -0.25)$  together with the lateral displacement and amplitude variation of the corresponding MF. Let  $c_{s_2}$  and  $a_{s_2}$  be the right and the left extreme of the  $s_i$  support, and  $Sup_{s_2}$  be its size. The support of the new label  $s'_2 = (s_2, -0.3, -0.25)$ , can be computed in the following way:

$$Sup_{s'_2} = Sup_{s_2} + \beta * Sup_{s_2}, \quad \text{with } Sup_{s_2} = c_{s_2} - a_{s_2}.$$

In [5], two different rule representation approaches were proposed for the LA-tuning of MFs, a global approach and a local a approach. In our case, the tuning is applied to the

level of linguistic partitions (global approach). In this way, the pair  $(X_j, \text{label})$  takes the same tuning values in all the rules where it is considered. For example,  $X_j$  is (High, 0.3, 0.1) will present the same values for those rules in which the pair “ $X_j$  is High” was initially considered. Notice that, since symmetrical triangular MFs and a FITA (*First Infer, Then Aggregate*) fuzzy inference was considered (the same presented in Sect. 2.1), a tuning of the amplitude of the consequents has no sense, by which the  $\beta$  parameter will be applied only on the antecedents.

In the context of FRBSs, considering the same control problem of Sect. 2.1, an example of a 3-tuples represented rule is (amplitude variation only applied in the antecedents):

$R_i$ : If the **error** is (Zero, 0.3, 0.1) and the  $\nabla$ **Error** is (Positive,  $-0.2$ ,  $-0.4$ ). Then the **Power** is (High,  $-0.1$ ).

Analysed from the rule interpretability point of view, we could interpret the lateral displacement as said in Sect. 2.1. However, it is not clear a meaning for the amplitude factor  $\beta$ . In this way, if the final MFs are more or less well distributed and no strong amplitude changes have been performed, an expert could perhaps rename these labels giving them a more or less representative meaning. In any case, the tuning of the support amplitude keeps the shape of the MFs (triangular and symmetrical). In this way, from the parameters  $\alpha$  and  $\beta$  applied to each linguistic label, we could obtain the equivalent triangular MFs, by which the last tuned FRBS could be finally represented as a classic Mamdani FRBS [28, 29].

Both approaches, lateral tuning and LA-tuning, present a good trade-off between interpretability and accuracy. However, this approach is closer to the accuracy than the lateral tuning, being this last closer to the interpretability. The choice between how interpretable and how accurate the model must be, usually depends on the user’s preferences for a specific problem and it will condition the selection of the type of tuning considered (lateral or LA-tuning).

In this case, the search space increases with respect to the lateral tuning of MFs, making more difficult the derivation of optimal models. However, this approach still involves a reduction of the search space with respect to the classic tuning (one less parameter per MF), which is still well handled by means of a smart use of the search technique.

### 3.2 Algorithm for the LA-tuning

To perform an LA-tuning of FLCs obtained by experts we consider the same algorithm presented in Sect. 2.2 for the lateral tuning of MFs by changing the coding scheme to also consider the amplitude parameters.

In this case, the coding scheme consists in the joining of the parameters of the fuzzy partitions, lateral ( $C^L$ ) and amplitude ( $C^A$ ) tuning. Let us consider the following number

of labels per variable:  $(m^1, \dots, m^n)$ , with  $n$  being the number of system variables ( $n - 1$  input variables and 1 output variable). Next, a chromosome has the following form (where each gene is associated to the tuning value of the corresponding label),

$$C_T = (C^L + C^A),$$

$$C^L = (c_{11}^L, \dots, c_{1m^1}^L, \dots, c_{n1}^L, \dots, c_{nm^n}^L),$$

$$C^A = (c_{11}^A, \dots, c_{1m^1}^A, \dots, c_{(n-1)1}^A, \dots, c_{(n-1)m^{n-1}}^A).$$

See the  $C_T$  part of Fig. 6 (in the next section) for a graphical example of coding scheme considering this approach.

## 4 Interaction between rule selection and the tuning approaches

Sometimes, a large number of fuzzy rules must be used to reach an acceptable degree of accuracy. However, an excessive number of rules makes it difficult to understand the model operation. Moreover, we may find different kinds of rules in a large fuzzy rule set: *irrelevant rules*, which do not contain significant information; *redundant rules*, whose actions are covered by other rules; *erroneous rules*, which are incorrectly defined and distort the FRBS performance; and *conflicting rules*, which perturb the FRBS performance when they coexist with others. These kinds of rules are usually obtained in non trivial problems when the final RB is generated by only considering the expert’s knowledge.

To face this problem, a fuzzy rule set reduction process can be developed to achieve the goal of minimizing the number of rules used while maintaining (or even improving) the FRBS performance. To do that, erroneous and conflicting rules that degrade the performance are eliminated, obtaining a more cooperative fuzzy rule set and therefore involving a potential improvement in the system accuracy. Moreover, in many cases accuracy is not the only requirement of the model but also interpretability becomes an important aspect. Reducing the model complexity is a way to improve the system readability, i.e., a compact system with few rules requires a minor effort to be interpreted.

Fuzzy rule set reduction is generally applied as a post-processing stage, once an initial fuzzy rule set has been derived. We may distinguish between two main different approaches to obtain a more *compact* fuzzy rule set:

- *Selecting fuzzy rules*—This involves obtaining an optimal subset of fuzzy rules from a previous fuzzy rule set by selecting some of them. We may find several methods in rule selection, with different search algorithms that look for the most successful combination of fuzzy rules [10, 21, 22, 25].

In [26], an interesting heuristic rule selection procedure is proposed where, by means of statistical measures,

a relevance factor is computed for each fuzzy rule in the linguistic FRBSs to subsequently select the most relevant ones. The philosophy of ordering the fuzzy rules with respect to an importance criterion and selecting a subset of the best seems something similar to the well-known orthogonal transformation-methods considered by Takagi-Sugeno-type FRBSs [33, 34].

- *Merging fuzzy rules*—This is an alternative approach that reduces the fuzzy rule set by merging the existing rules. In [27], the authors propose merging neighbouring rules, i.e., fuzzy rules where the linguistic terms used by the same variable in each rule are adjacent. Another proposal is presented in [19], where a special consideration to the merging order is made. In Takagi-Sugeno-type FRBSs, processes that simplify the fuzzy models by merging fuzzy rules have also been proposed [30–32].

These kinds of techniques for rule reduction could easily be combined with other post-processing techniques to obtain more compact and accurate FRBSs. In this way, several works have considered the selection of rules together with the tuning of MFs by coding all of them (fuzzy rules and tuning parameters) within the same chromosome [9, 15].

#### 4.1 Positive synergy between both approaches

There are several reasons explaining the positive synergy between the rule selection and the tuning of MFs. Some of them are:

- The tuning process is affected when erroneous or conflictive rules are included in the initial RB. When the RB of a model being tuned contains bad rules (greatly increasing the system error), the tuning process tries to reduce the effect of these kinds of rules, adapting them and the remaining ones to avoid the bad performance of such rules. This way of working imposes strict restrictions, reducing the process ability to obtain precise linguistic models. Furthermore, in some cases this also affects the interpretability of the model, since the MFs comprising bad rules do not have the shape and location which best represents the information being modelled.

This problem grows as the problem complexity grows (i.e., problems with a large number of variables and/or rules) and when the rule generation method does not ensure the generation of rules with good quality (e.g., when the initial RB is obtained by experts). In these cases, the tuning process is very complicated because the search ability is dedicated to reducing the bad performance of some rules instead of improving the performance of the remaining ones. In these cases, rule selection could help the tuning mechanism by removing the rules that really degrade the accuracy of the model.

- Sometimes redundant rules can not be removed by only using a rule selection method, since these kinds of rules could reinforce the action of poor rules improving the model accuracy. The tuning of MFs can change the performance of these rules making the reinforcement action unnecessary, and therefore, helping the rule selection technique to remove redundant rules.

Therefore, combining rule selection and tuning approaches could cause important improvements in the system accuracy, maintaining the interpretability at an acceptable level [3, 9, 15]. However, in some cases, the search space considered when both techniques are combined is too large, which could provoke the derivation of sub-optimal models [9].

In this section, we propose the selection of a cooperative set of rules from a candidate fuzzy rule set together with the lateral or LA-tuning. This pursues the following aims:

- To improve the linguistic model accuracy selecting the set of rules best cooperating while lateral or LA-tuning is performed to improve the global configuration of MFs.
- To obtain simpler, and thus easily understandable, linguistic models by removing unnecessary or unimportant rules.
- To favour the combined action of the tuning and rule selection strategies (which involves a larger search space) by considering the simpler search space of the lateral or LA-tuning (only one or two parameters per label).

#### 4.2 Algorithms for tuning and rule selection

To select the subset of rules which cooperate best and to obtain the tuning parameters, we consider a GA which codes all of them (rules and parameters) in one chromosome. In this way, we present two methods (one performing lateral tuning and the other performing LA-tuning) that are based on the algorithms proposed in Sects. 2.2 and 3.2, again considering the steady-state approach [35].

To do so, we must take into account the existence of binary genes (rule selection) and real values within the same chromosome. Therefore, the algorithms proposed in Sects. 2.2 and 3.2 are changed in order to consider a double coding scheme and to apply the appropriate genetic operators for each chromosome part. The following changes are considered in both algorithms in order to integrate the reduction process with the tuning of MFs:

- *Coding Scheme*—A double coding scheme for both tuning of parameters and rule selection is considered:

$$C = C_T + C_S.$$

In this case, the previous approaches (part  $C_T$ ) are combined with the rule selection by allowing an additional binary vector  $C_S$  that directly determines when a rule is selected or not (alleles ‘1’ and ‘0’ respectively).

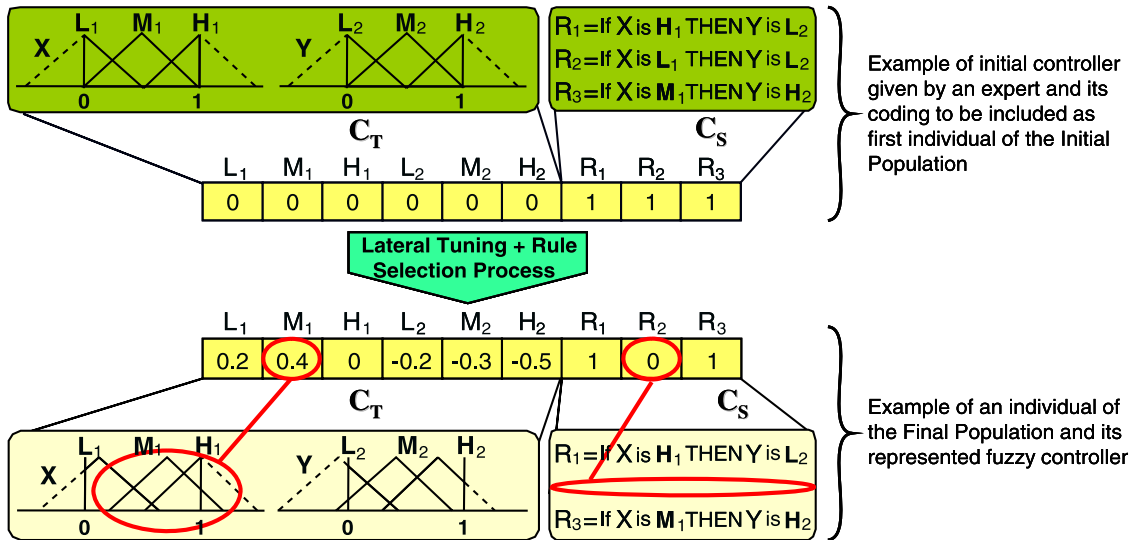

Fig. 5 Example of coding scheme considering lateral tuning and rule selection

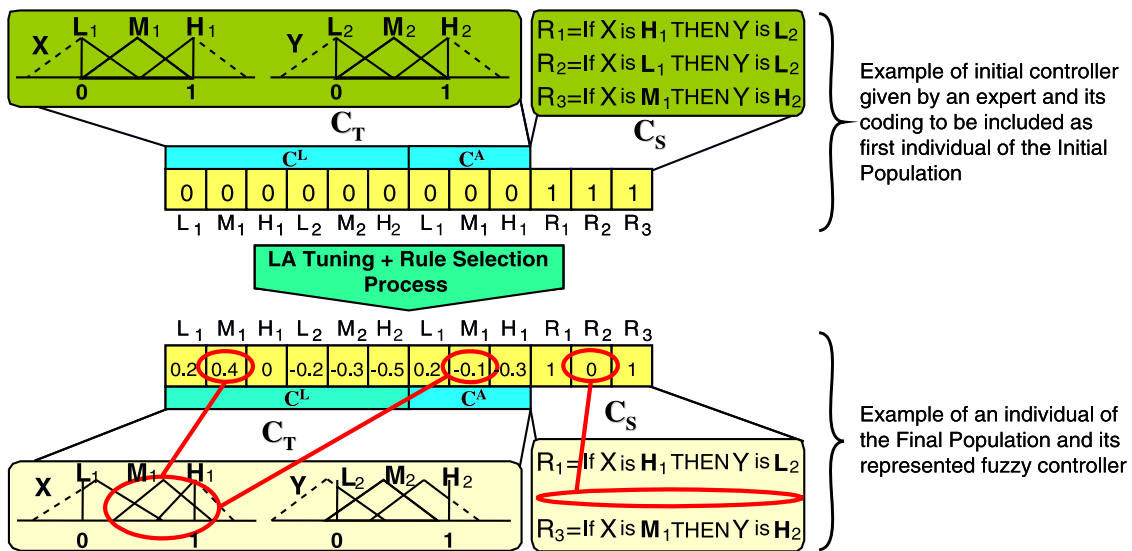

Fig. 6 Example of coding scheme considering LA-tuning and rule selection

Considering the  $M$  rules contained in the preliminary/candidate rule set, the chromosome part,

$$C_S = (c_1, \dots, c_M),$$

represents the subset of rules composing the final rule base, such that:

$$\text{If } c_i = 1 \text{ then } (R_i \in \text{RB}) \text{ else } (R_i \notin \text{RB}),$$

with  $R_i$  being the corresponding  $i$ th rule in the candidate rule set and RB the final rule base. Figures 5 and 6 respectively show an example of correspondence between a chromosome and its associated KB considering the lateral tuning and considering the LA-tuning.

- *Initial gene pool*—The initial pool is obtained with an individual having all genes with value ‘0.0’ in the  $C_T$  part and ‘1’ in the  $C_S$  part, and the remaining individuals generated at random in  $[-0.5, 0.5]$  and  $\{0, 1\}$  respectively.

- *Crossover*—The crossover operator presented in Sect. 2.2 for the  $C_T$  part combined with the standard two-point crossover in the  $C_S$  part. The two-point crossover operator involves exchanging the fragments of the parents contained between two points selected at random, resulting in two different offspring. In this case, four offspring are generated by combining the two from the  $C_T$  part with the two from the  $C_S$  part. The two best offspring obtained in this way are finally considered as the two corresponding descendents.



**Fig. 7** Generic structure of an office building HVAC system

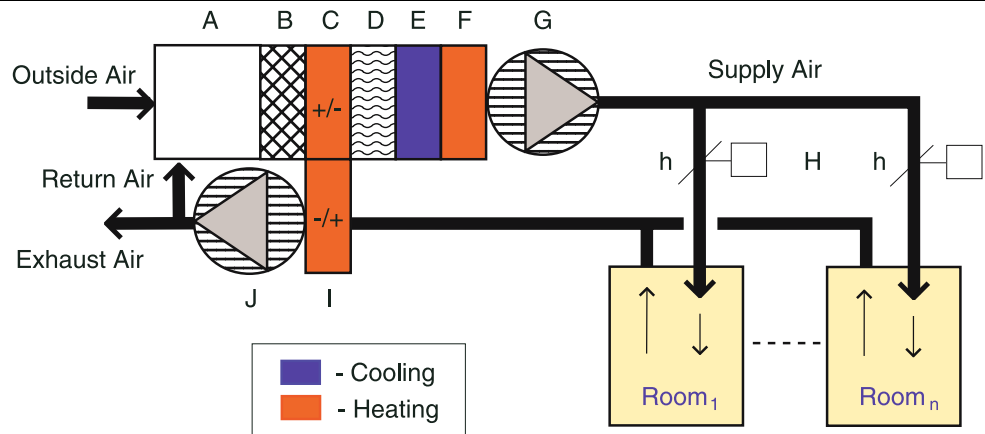

– *Mutation*—A mutation operator is applied on the  $C_S$  part of the four offspring before selecting the two descendants. This operator flips a gene value in  $C_S$  and helps to avoid a premature convergence in this part of the chromosome.

The application of these changes on the algorithms proposed in Sects. 2.2 and 3.2 gives rise to two different algorithms: Lateral Tuning + Rule Selection and LA – tuning + Rule Selection.

## 5 A case study: the HVAC system control problem

In EU countries, primary energy consumption in buildings represents about 40% of total energy consumption and more than a half of this energy is used for indoor climate conditions. On a technological point of view, it is estimated that the consideration of specific technologies like Building Energy Management Systems (BEMSs) can save up to 20% of the energy consumption of the building sector, i.e., 8% of the overall Community consumption. With this aim, BEMSs are generally applied only to the control of active systems, i.e., HVAC systems.

An HVAC system is comprised by all the components of the appliance used to condition the interior air of a building. The HVAC system is needed to provide the occupants with a comfortable and productive working environment which satisfies their physiological needs. In Fig. 7, a typical office building HVAC system is presented. This system consists of a set of components that make it possible to raise and to reduce the temperature and relative humidity of the air supply.

The energy consumption as well as indoor comfort aspects of ventilated and air conditioned buildings are highly dependent on the design, performance and control of their HVAC systems and equipments. Therefore, the use of appropriate automatic control strategies, as FLCs, for HVAC systems control could result in important energy savings when they are compared to manual control [1, 20].

Some artificial intelligence techniques could be successfully applied to enhance the HVAC system capabilities [8, 20]. However, most works apply FLCs to individually solve simple problems such as thermal regulation (maintaining the temperature at a set point), energy savings or comfort improvements. On the other hand, the initial rule set is usually constructed based on the operator's control experience using rules of thumb, which sometimes fail to obtain satisfactory results [20]. Therefore, the different involved criteria should be optimized for a good performance of the HVAC System. Usually, *the main objective is to reduce the energy consumption maintaining a desired comfort level.*

In our case, five criteria should be optimized improving an initial FLC obtained from human experience (involving 17 variables) by the application of the proposed technique for the lateral tuning of the MFs and rule selection. To do so, we consider a well calibrated and well validated model of a real test building. Both, the initial FLC and the simulation model were developed within the framework of the JOULE-THERMIE programme under the GENESYS<sup>1</sup> project. From now on, this test building will be called the GENESYS test site.

In the following subsections the five different objectives and the final fitness function to be optimized will be presented together with the initial FLC architecture and variables (see [1] for a more detailed information on this problem).

### 5.1 Objectives and fitness function

*Our main optimization objective is the energy performance but maintaining the required indoor comfort levels.* In this

<sup>1</sup>GENESYS Project: Fuzzy controllers and smart tuning techniques for energy efficiency and overall performance of HVAC systems in buildings, European Commission, Directorate-General XII for Energy (contract JOE-CT98-0090).

way, the global objective is to *minimize* the following five criteria:

- O<sub>1</sub>** Upper thermal comfort limit: if  $PMV > 0.5$ ,  $O_1 = O_1 + (PMV - 0.5)$ , where PMV is the more global Predicted Mean Vote thermal comfort index 7730 selected by the international standard organization ISO, incorporating relative humidity and mean radiant temperature.<sup>2</sup>
- O<sub>2</sub>** Lower thermal comfort limit: if  $PMV < -0.5$ ,  $O_2 = O_2 + (-PMV - 0.5)$ .
- O<sub>3</sub>** Indoor air quality requirement: if  $CO_2 \text{ conc.} > 800 \text{ ppm}$ ,  $O_3 = O_3 + (CO_2 - 800)$ .
- O<sub>4</sub>** Energy consumption:  $O_4 = O_4 + \text{Power at time } t$ .
- O<sub>5</sub>** System stability:  $O_5 = O_5 + \text{System change from time } t \text{ to } (t - 1)$ , where system change states for a change in the system operation, e.g., it counts the system operation changes (a change in the fan coil speed, extract fan speed or valve position adds 1 to the final count).

In our case, these criteria are combined into one overall objective function by means of a vector of weights. This technique (objective weighting) has much sensitivity and dependency toward weights. However, when trusted weights are available, this approach reduces the size of the search space providing the adequate direction into the solution space and its use is highly recommended. Since trusted weights were obtained from experts, we followed this approach.

Hence, an important outcome was to assign appropriate weights to each criterion of the fitness function. Although it is not part of this work and these weights were obtained within the framework of the GENESYS project, the basic idea in this weight definition was to find financial equivalents for all of them. Such equivalences are difficult to define and there is a lack of confident data on this topic. Whereas energy consumption cost is easy to set, comfort criteria are more difficult. Several studies have shown that a 18% improvement in people’s satisfaction about indoor climate corresponds to a 3% productivity improvement for office workers. Based on typical salaries and due to the fact that PMV and CO<sub>2</sub> concentrations are related to people’s satisfaction, such equivalences can be defined. The same strategy can be applied to the systems stability criterion, life-cycle of various systems being related to number of operations. Based on this, weights can be obtained for each specific building (test site). Thus, trusted weights were obtained by the experts for the objective weighting fitness function:  $w_1^O = 0.0083022$ ,  $w_2^O = 0.0083022$ ,  $w_3^O = 0.00000456662$ ,  $w_4^O = 0.0000017832$  and  $w_5^O =$

0.000761667. Finally, the fitness function that has to be minimized was computed as:

$$F = \sum_{i=1}^5 w_i^O \cdot O_i.$$

However, the fitness function has been modified in order to also consider the use of fuzzy goals that decrease the importance of each individual fitness value whenever it reaches its goal or penalize each objective whenever its value gets worse with respect to the initial solution. To do so, a function modifier parameter is considered,  $\delta_i(x)$  (taking values over 1.0). A penalization rate,  $p_i$ , has been included in  $\delta_i(x)$ , allowing the user to set up priorities in the objectives (with 0 representing less priority and 1 more priority). Therefore, the global fitness is evaluated as:

$$F' = \sum_{i=1}^5 w_i^O \cdot \delta_i(O_i) \cdot O_i.$$

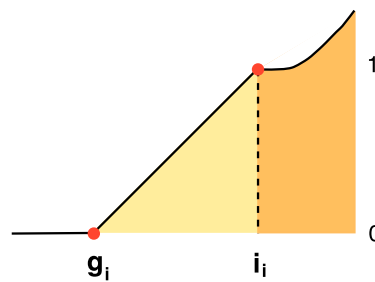

$$\delta_i(x) = \begin{cases} 0, & \text{if } x \leq g_i, \\ \frac{x - g_i}{i_i - g_i}, & \text{if } g_i < x < i_i, \\ \frac{x - i_i}{x - x \cdot p_i} + 1, & \text{if } i_i \leq x. \end{cases}$$

**Fig. 8**  $\delta_i(x)$  when  $g_i \leq i_i$

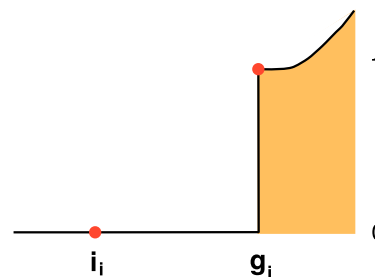

$$\delta_i(x) = \begin{cases} 0, & \text{if } x < i_i, \\ \frac{x - g_i}{x - x \cdot p_i} + 1, & \text{if } g_i \leq x. \end{cases}$$

**Fig. 9**  $\delta_i(x)$  when  $g_i > i_i$

<sup>2</sup><http://www.iso.org/iso/en/ISOOnline.frontpage>

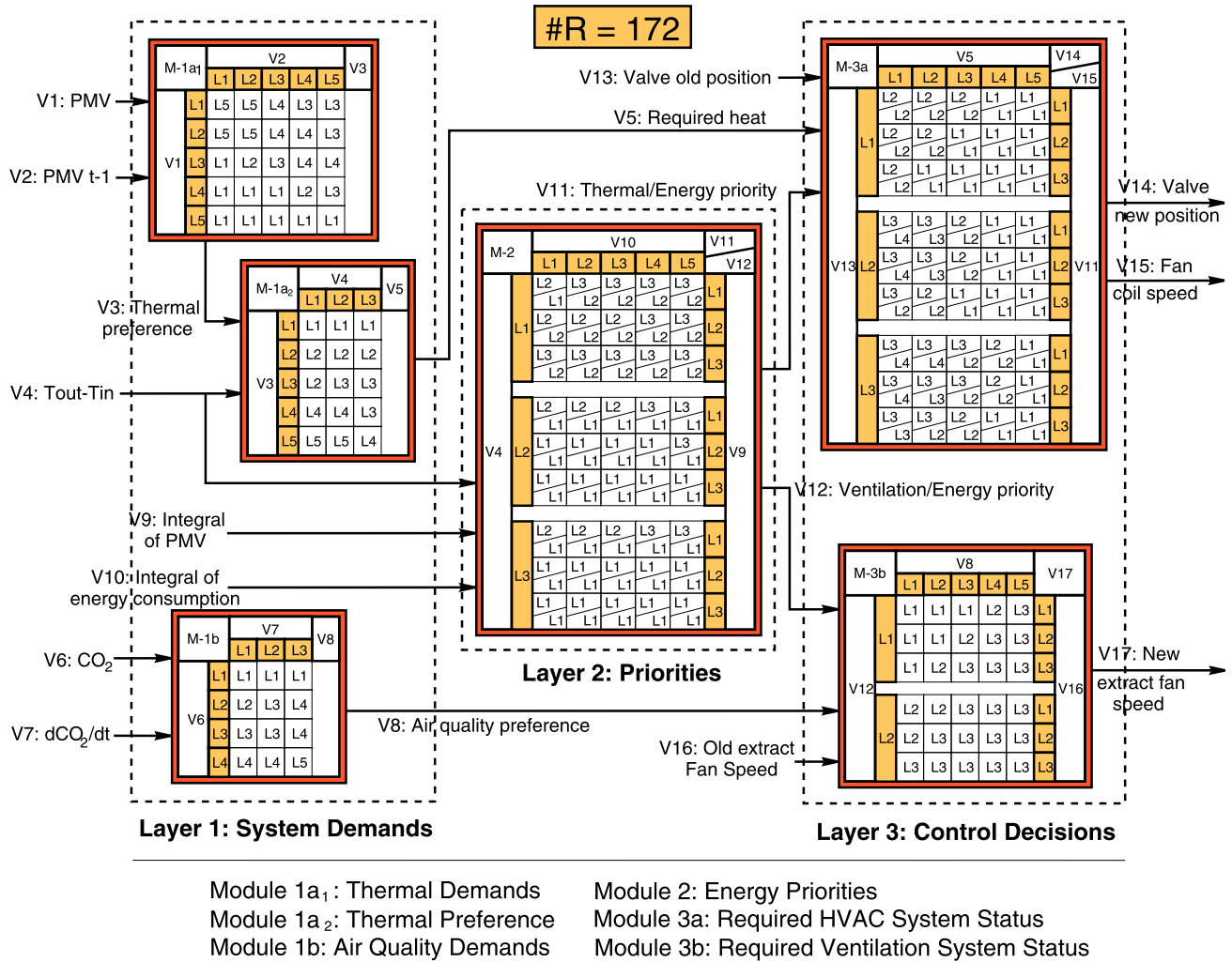

Fig. 10 Initial RB and generic structure of the GENESYS FLC

Two situations can be presented according to the value of the goal  $g_i$ , and the value of the initial solution  $i_i$ . Depending on these values, two different  $\delta$  functions will be applied:

- When the value of  $g_i$  is minor than the value of  $i_i$ , the objective is not considered if the goal is met and penalized if the initial results get worse (see Fig. 8).
- When the value of  $i_i$  is minor than the value of  $g_i$ , this initial result may get worse while the goal is met and, it is penalized otherwise (see Fig. 9).

5.2 FLC variables and architecture

A hierarchical FLC architecture considering the PMV, CO<sub>2</sub> concentration, previous HVAC system status and outdoor temperature was proposed by the BEMS designer for this site. This architecture, variables and initial RB are presented in Fig. 10. There are three different parts (layers) in the proposed structure. The first one is devoted to the system demands, i.e., this layer analyzes the current system state and

determines the required heat and the air quality preference in order to ensure a good comfort level. The second one analyzes the trend of the system in terms of PMV and energy consumption, also taking into account the outdoor and indoor temperatures in order to determine whether the system should save energy or to spend some energy to achieve a better thermal point or to perform ventilation. Finally, the third one determines the operation mode (manipulating three actuators) by taking into account the current state of the actuators and the system preferences and priorities determined by layers 1 and 2. A more detailed description of the variables considered in the initial FLC structure can be found at [1].

The DB is composed of symmetrical fuzzy partitions with triangular-shaped MFs labelled from  $L_1$  to  $L_i$  (with  $i$  being the number of labels of the  $i$ th variable). The initial DB is depicted in Fig. 11 together with the tuned DB. Figure 10 represents the decision tables of each module of the hierarchical FLC in terms of these labels. Each cell of the table represents a fuzzy subspace and contains its asso-

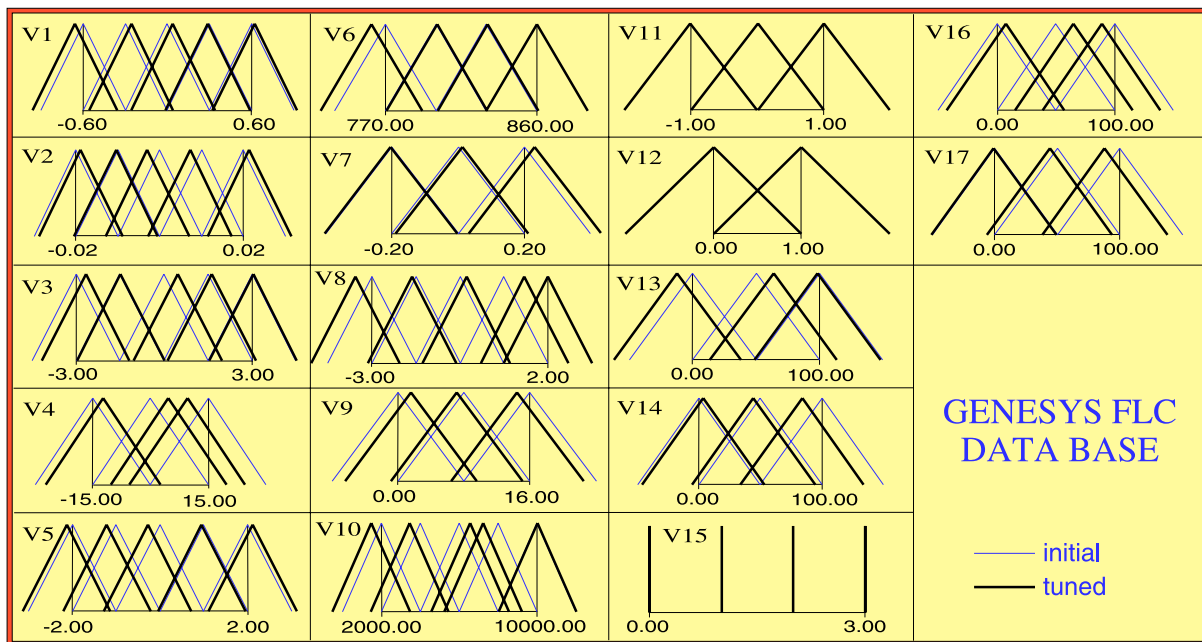

**Fig. 11** Initial and tuned DB of a model obtained with GL-S (seed 1)

ciated output consequent(s), i.e., the corresponding label(s). The output variables are denoted in the top left square for each module in the figure. Both, the initial RB and the DB, were provided by the BEMS designer.

## 6 Experiments

To evaluate the correctness of the approaches presented in the previous sections, the HVAC problem is considered in order to be solved. The FLCs obtained from these approaches will be compared to the performance of a classic On-Off controller and to the performance of the initial FLC (provided by experts). *The goals and improvements will be computed with respect to this classic controller as done in the GENESYS project.* The experts intention was to try to have a 10% of energy saving ( $O_4$ ) together with a global improvement of the system behaviour compared to On-Off control. Comfort parameters could be slightly increased if necessary (no more than 1.0 for criteria  $O_1$  and  $O_2$ ). The methods considered in this study are shown in Table 1. S only performs rule selection ( $C_S$  part of GL-S or GLA-S) and was first used for this problem in [2] in order to be compared with a method performing rule weighting and rule selection together (although this other method, rule weighting and selection, is not comparable we can point out that the results obtained by it are so far of the results presented in this work). C performs classic tuning and was first used for this problem in [1] as a first result from the GENESYS project. C-S has been not used before in this problem and it

has been developed only for comparison purposes. The remaining approaches are those presented in this paper.

The values of the parameters used in all of these experiments are presented in the following: 31 individuals, 0.2 as mutation probability per chromosome (except for GL and GLA without mutation), 0.3 for the factor  $\alpha$  in the hybrid crossover operator and 0.35 as factor  $a$  in the max-min-arithmetic crossover in the case of C. The termination condition is to reach 2000 evaluations in all the cases, in order to perform a fair comparative study. In order to evaluate the GA good convergence, three different runs have been performed considering three different seeds for the random number generator.

The results presented in Table 2, where % stands for the improvement rate with respect to the On-Off controller for each criterion and #R for the number of fuzzy rules, correspond to averaged results obtained from the three different runs. The results obtained with the On-Off and the initial FLC controller are also included in this table. No improvement percentages have been considered in the table for  $O_1 \dots O_3$ , since these objectives have always met the experts requirements (goals) and the On-Off controller presents zero values for these objectives.

A good trade-off between energy and stability was achieved for all the new models obtained considering the LA-tuning or rule selection (GL-S, GLA and GLA-S) except that considering classic tuning, with the remaining criteria for comfort and air quality within the requested levels. GL-S presents improvement rates of about 28.6% in energy and about 29.6% in stability. In the same way, GLA presents

**Table 1** Methods considered for comparison

Method	Ref.	Year	Description
S	[2]	2005	Rule selection ( $C_S$ part of GL-S)
C	[1]	2003	Classic tuning
C-S	–	–	Classic tuning + rule selection
GL	–	–	Global lateral tuning
GL-S	–	–	GL + rule selection
GLA	–	–	Global LA-tuning
GLA-S	–	–	GLA + rule selection

**Table 2** Comparison among the different methods

Model	#R	PMV		CO <sub>2</sub>	Energy		Stability	
		$O_1$	$O_2$		$O_3$	$O_4$	%	$O_5$
On-Off	–	0.0	0	0	3206400	–	1136	–
Initial FLC	172	0.0	0	0	2901686	9.50	1505	–32.48
$\bar{S}$	160	0.1	0	0	2886422	9.98	1312	–15.52
$\bar{C}$	172	0.0	0	0	2586717	19.33	1081	4.84
$\bar{C} - \bar{S}$	109	0.1	0	0	2536849	20.88	1057	6.98
$\bar{GL}$	172	0.9	0	0	2325093	27.49	1072	5.66
$\bar{GL} - \bar{S}$	113	0.7	0	0	2287993	28.64	800	29.58
$\bar{GLA}$	172	0.9	0	0	2245812	<b>29.96</b>	797	29.84
$\bar{GLA} - \bar{S}$	<b>104</b>	0.8	0	0	2253996	29.70	634	<b>44.19</b>

improvement rates of about 29.9% in energy and 29.8% in stability and GLA-S even improves the system stability up to 44.2% by only considering 100 rules approximately. Moreover, these algorithms (including GL) present a good convergence and seem to be independent of random factors.

Taking into account the differences among the results obtained by considering classic tuning (C and C-S) and those considering lateral or LA-tuning we can point out that, in complex problems (problems in which to obtain a set with cooperative rules is non trivial for an expert), the search space is too large to obtain a good global configuration of the MFs and rules. In this manner, consider ring techniques to ease the way to obtain a more global optimum can take advantage with respect to other approaches with more freedom degrees but handling too large search spaces.

Besides, we have to highlight that the best results obtained from those methods considering rule selection with much less rules indicate that there are a lot of rules that are wrong or not necessary in the initial RB provided by an expert. Probably, many of them are contradictory rules forcing the HVAC system to continuously change its way of working instead of maintaining a stable operation mode.

Figures 11 and 12 represent the initial and final DB of a FLC obtained by GL-S and GLA-S (seed 1). They show that not so strong variations in the MFs can involve important improvements. Moreover, Fig. 13 represents the corresponding decision tables of the model obtained from GLA-S

with seed 1. In this case, a large number of rules have been removed from the initial FLC, obtaining much simpler models (72 rules were removed). This fact improves the system readability, and allows us to obtain more simple and accurate FLCs.

### 7 Concluding remarks

In this work, we propose the use of two advanced tuning techniques (lateral and LA-tuning) and their combination with rule selection to improve FLCs obtained by experts in non trivial problems. A case study for the control of HVAC systems has been considered in order to apply these new techniques. From the results obtained we can point out the following conclusions:

- In these kinds of non trivial problems, the search space reduction that lateral and LA-tuning involve allows the considered optimization technique to obtain more optimal FLCs respect with a classic approach with more freedom degrees.
- In our opinion, a rule selection technique is necessary when an initial FLC obtained by experts is considered to be improved. Usually, a RB obtained by experts includes conflicting and redundant rules that should be removed

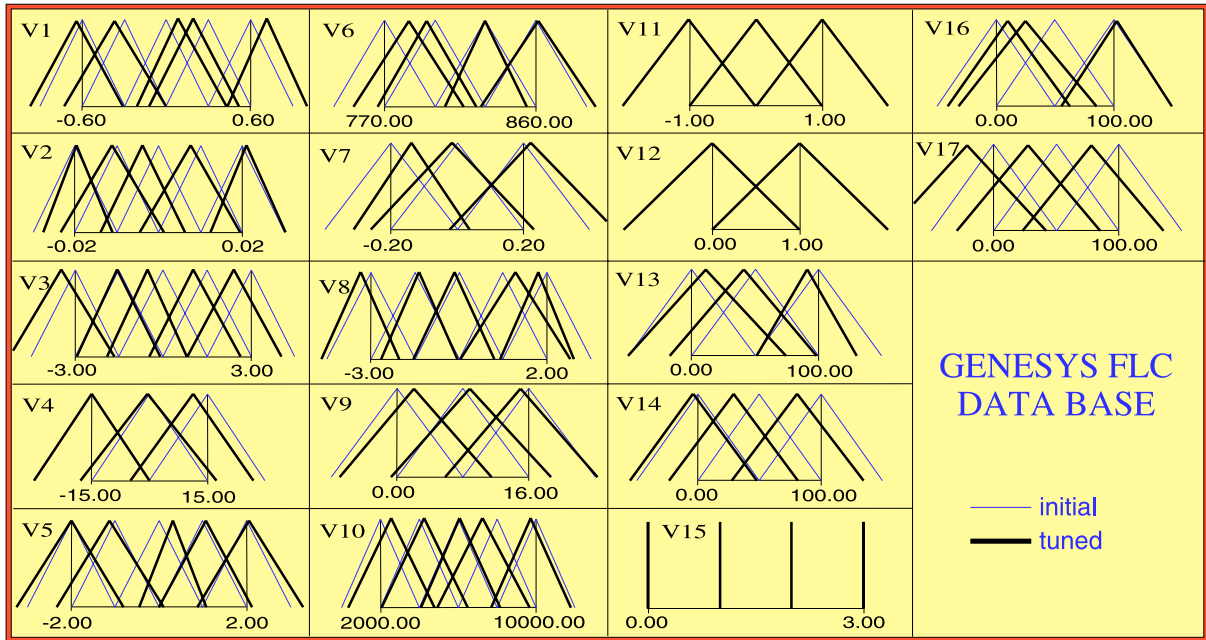
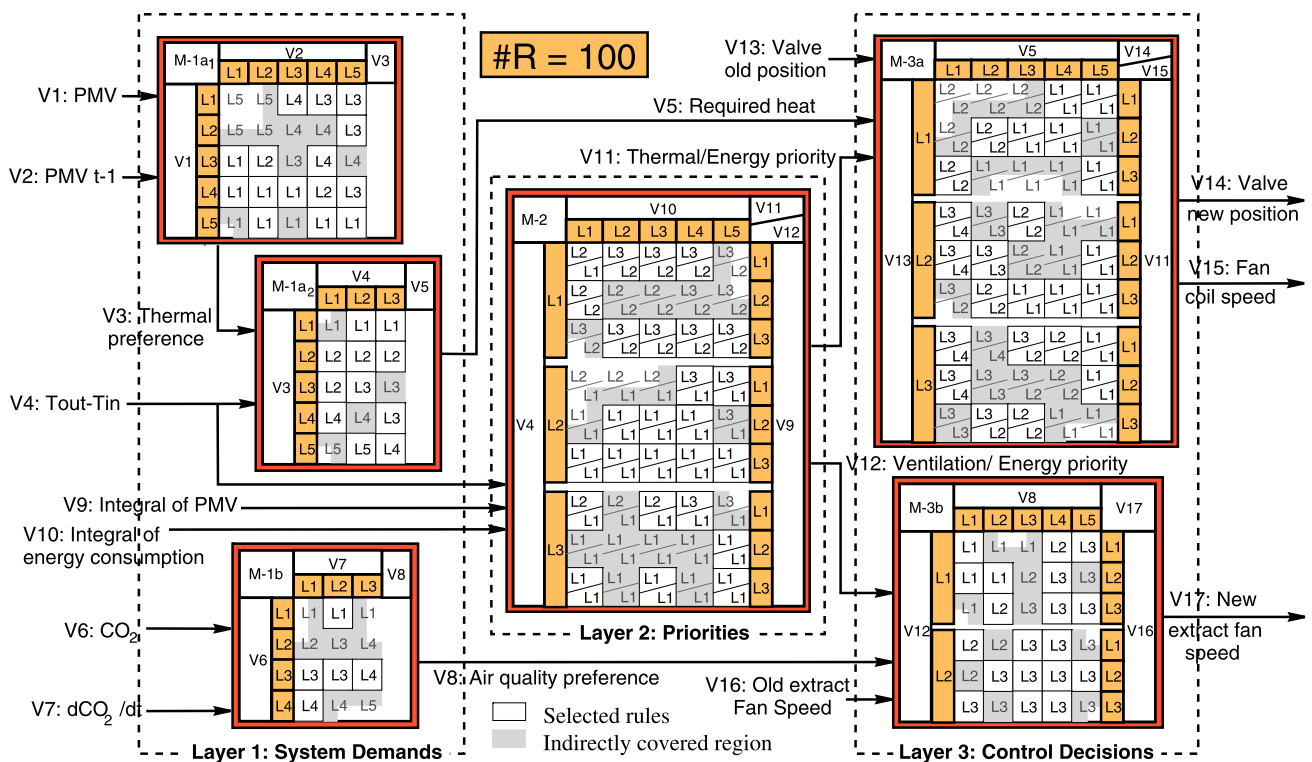

Fig. 12 Initial and tuned DB of a model obtained with GLA-S (seed 1)



**Modules:** Module 1a<sub>1</sub>: Thermal Demands      Module 2: Energy Priorities  
 Module 1a<sub>2</sub>: Thermal Preference      Module 3a: Required HVAC System Status  
 Module 1b: Air Quality Demands      Module 3b: Required Ventilation System Status

Fig. 13 RB and final structure of a model obtained with GLA-S (seed 1)

and, in any case, when this technique is guided by accuracy measures no rules will be removed if that worsen the system performance.

- The search space reduction provided by the lateral and the LA-tuning helps to better handle the larger search space that the combination between rule selection and tuning techniques involves, taking advantage respect to the classic approach.

As mentioned, tuning is a variation in the shape of the MFs that improves their global interaction with the main aim of inducing better cooperation among the rules. In this way, the real aim of the tuning is to find the best global configuration of the MFs and not only to find independently specific MFs. The main difference of lateral and LA-tuning with the classic approach is the reduction of the search space focusing the search only on the MF support position. Although lateral and LA-tuning have less freedom than the classic approach, the reduction of the search space could lead to improved performance of the tuning method, especially in complex or highly multidimensional problems, since this allows us to obtain easily the best *global interaction* between the MFs, thereby ensuring a good performance of the obtained controllers. The use of these new techniques is then justifiable when the classic approach is not able to obtain this global configuration due to the existence of a very large or complex search space. This is the case of the technique presented in [6] based on the 2-tuples representation to learn the whole knowledge base (number of MFs, rule base and parameters all together), which itself represent a very complex search space independently of the problem being solved. Unfortunately, this technique can not be applied to these kinds of problems based on an initial rule base obtained from experts since the rule base extraction is completely based on the existence of example data, and they are not usually available in these kinds of problems.

As further work, we propose the use of multiobjective GAs in order to obtain even simpler FLCs but maintaining a similar accuracy, which represent an even more complex search space.

**Acknowledgements** Supported by the Spanish Ministry of Education and Science under grant No. TIN2005-08386-C05-01, and the Andalusian government under grant No. P05-TIC-00531.

## References

1. Alcalá R, Benítez JM, Casillas J, Cordon O, Pérez R (2003) Fuzzy control of HVAC systems optimized by genetic algorithms. *Appl Intell* 18:155–177
2. Alcalá R, Casillas J, Cordon O, González A, Herrera F (2005) A genetic rule weighting and selection process for fuzzy control of HVAC systems. *Eng Appl Artif Intell* 18(3):279–296
3. Alcalá R, Alcalá-Fdez J, Casillas J, Cordon O, Herrera F (2006) Hybrid learning models to get the interpretability-accuracy trade-off in fuzzy modeling. *Soft Comput* 10(9):717–734
4. Alcalá R, Alcalá-Fdez J, Herrera F (2007) A Proposal for the genetic lateral tuning of linguistic fuzzy systems and its interaction with rule selection. *IEEE Trans Fuzzy Syst* 15(4):616–635
5. Alcalá R, Alcalá-Fdez J, Gacto MJ, Herrera F (2007) Rule base reduction and genetic tuning of fuzzy systems based on the linguistic 3-tuples representation. *Soft Comput* 11(5):401–419
6. Alcalá R, Alcalá-Fdez J, Herrera F, Otero J (2007) Genetic learning of accurate and compact fuzzy rule based systems based on the 2-tuples linguistic representation. *International J Approx Reason* 44(1):45–64
7. Babuška R, Oosterhoff J, Oudshoorn A, Bruijn PM (2002) Fuzzy self-tuning PI control of pH in fermentation. *Eng Appl Artif Intell* 15(1):3–15
8. Calvino F, Gennusa ML, Rizzo G, Scaccianoce G (2004) The control of indoor thermal comfort conditions: introducing a fuzzy adaptive controller. *Energy Build* 36:97–102
9. Casillas J, Cordon O, Del Jesus MJ, Herrera F (2005) Genetic tuning of fuzzy rule deep structures preserving interpretability and its interaction with fuzzy rule set reduction. *IEEE Trans Fuzzy Syst* 13(1):13–29
10. Cordon O, Herrera F (2000) A proposal for improving the accuracy of linguistic modeling. *IEEE Trans Fuzzy Syst* 8(3):335–344
11. Cordon O, Herrera F, Hoffmann F, Magdalena L (2001) Genetic fuzzy systems: Evolutionary tuning and learning of fuzzy knowledge bases. World Scientific, Singapore
12. Driankov D, Hellendoorn H, Reinfrank M (1993) An introduction to fuzzy control. Springer, Berlin
13. Eshelman LJ (1991) The CHC adaptive search algorithm: How to have safe search when engaging in nontraditional genetic recombination. In: *Foundations of Genetic Algorithms*, vol 1. Morgan Kaufman, San Mateo, pp 265–283
14. Eshelman LJ, Schaffer JD (1993) Real-coded genetic algorithms and interval-schemata. *Found Genet Algorithms* 2:187–202
15. Gómez-Skarmeta AF, Jiménez F (1999) Fuzzy modeling with hybrid systems. *Fuzzy Sets Syst* 104:199–208
16. Herrera F, Martínez L (2000) A 2-tuple fuzzy linguistic representation model for computing with words. *IEEE Trans Fuzzy Syst* 8(6):746–752
17. Herrera F, Lozano M, Verdegay JL (1995) Tuning fuzzy logic controllers by genetic algorithms. *Int J Approx Reason* 12:299–315
18. Herrera F, Lozano M, Verdegay JL (1997) Fuzzy connectives based crossover operators to model genetic algorithms population diversity. *Fuzzy Sets Syst* 92(1):21–30
19. Hong TP, Lee CY (1999) Effect of merging order on performance of fuzzy induction. *Intell Data Anal* 3(2):139–151
20. Huang S, Nelson RM (1994) Rule development and adjustment strategies of a fuzzy logic controller for an HVAC system—parts I and II (Analysis and Experiment). *ASHRAE Trans* 100(1):841–856
21. Ishibuchi H, Murata T, Türksen IB (1997) Single-objective and two objective genetic algorithms for selecting linguistic rules for pattern classification problems. *Fuzzy Sets Syst* 89(2):135–150
22. Ishibuchi H, Nozaki K, Yamamoto N, Tanaka H (1995) Selecting fuzzy if-then rules for classification problems using genetic algorithms. *IEEE Trans Fuzzy Syst* 3(3):260–270
23. Jang JSR (1993) ANFIS: Adaptive network based fuzzy inference system. *IEEE Trans Syst Man Cybern* 23(3):665–684
24. Karr C (1991) Genetic algorithms for fuzzy controllers. *AI Expert* 6(2):26–33
25. Krone A, Krause H, Slawinski T (2000) A new rule reduction method for finding interpretable and small rule bases in high dimensional search spaces. *Proc IEEE Int Conf Fuzzy Syst* 2:693–699
26. Krone A, Taeger H (2001) Data-based fuzzy rule test for fuzzy modelling. *Fuzzy Sets Syst* 123(3):343–358

27. Klose A, Nurnberger A, Nauck D (1998) Some approaches to improve the interpretability of neuro-fuzzy classifiers. In: Proceedings of the 6th European congress on intelligent techniques and soft computing, pp 629–633
28. Mamdani EH (1974) Application of fuzzy algorithms for control of simple dynamic plant. Proc IEEE 121(12):1585–1588
29. Mamdani EH, Assilian S (1975) An experiment in linguistic synthesis with a fuzzy logic controller. Int J Man-Mach Stud 7:1–13
30. Setnes M, Babuška R, Kaymak U, van Nauta Lemke HR (1998) Similarity measures in fuzzy rule base simplification. IEEE Trans Syst Man Cybern B: Cybern 28(3):376–386
31. Setnes M, Roubos JA (2000) GA-fuzzy modeling and classification: complexity and performance. IEEE Trans Fuzzy Syst 8(5):509–522
32. Roubos JA, Setnes M (2001) Compact and transparent fuzzy models and classifiers through iterative complexity reduction. IEEE Trans Fuzzy Syst 9(4):516–524
33. Yam Y, Baranyi P, Yang CT (1999) Reduction of fuzzy rule base via singular value decomposition. IEEE Trans Fuzzy Syst 7:120–132
34. Yen J, Wang L (1999) Simplifying fuzzy rule-based models using orthogonal transformation methods. IEEE Trans Syst Man Cybern B: Cybern 29:13–24
35. Whitley D, Kauth J (1988) GENITOR: A different genetic algorithm. In: Proceedings of the Rocky Mountain conference on artificial intelligence, pp 118–130



**Rafael Alcalá** received the M.Sc. degree in Computer Science in 1998 and the Ph.D. degree in Computer Science in 2003, both from the University of Granada, Spain.

He is currently an Assistant Professor in the Department of Computer Science and Artificial Intelligence at the University of Granada, where he is a Member of the Soft Computing and Intelligent Information Systems Research Group.

He has over 43 international publications, 15 of them published in international journals. As edited activities, he has co-edited the IEEE Transactions on Fuzzy Systems Special Issue on “Genetic Fuzzy Systems: What’s next”. He has worked on several research projects supported by the Spanish government and the European Union. His research interests include, multi-objective genetic algorithms and genetic fuzzy systems, especially the learning/tuning of fuzzy systems for modeling and control with trade-off between interpretability and accuracy.



**Jesús Alcalá-Fdez** received the M.Sc. and Ph.D. degrees in computer science from the University of Granada, Spain, in 2002 and 2006, respectively.

He is currently an Assistant Professor in the Department of Computer Science and Artificial Intelligence, University of Granada, where he is a Member of the Soft Computing and Intelligent Information Systems Research Group in the Department of Computer Science and Artificial In-

telligence at the University of Granada. He has over 25 international publications, 12 of them published in international journals. He has worked on several research projects supported by the Spanish government.

As edited activities, he has co-edited the IEEE Transactions on Fuzzy Systems Special Issue on “Genetic Fuzzy Systems: What’s next”. His research interests include fuzzy association rules, data mining software, multiobjective genetic algorithms and genetic fuzzy systems, especially the learning/tuning of fuzzy systems for modeling and control with trade-off between interpretability and accuracy.



**María José Gacto** received the M.Sc. degree in Computer Science in 1999 from the University of Granada, Spain.

She is a Member of the Soft Computing and Intelligent Information Systems Research Group in the Department of Computer Science and Artificial Intelligence at the University of Granada. She has over 15 international publications. She has worked on several research projects supported by the Spanish government and the European Union.

Her research interests include, multi-objective genetic algorithms and genetic fuzzy systems, especially the learning/tuning of fuzzy systems for modeling and control with trade-off between interpretability and accuracy.



**Francisco Herrera** received the M.Sc. degree in Mathematics in 1988 and the Ph.D. degree in Mathematics in 1991, both from the University of Granada, Spain.

He is currently a Professor in the Department of Computer Science and Artificial Intelligence at the University of Granada. He has published more than 100 papers in international journals.

He is coauthor of the book “*Genetic Fuzzy Systems: Evolutionary Tuning and Learning of Fuzzy Knowledge Bases*” (World Scientific, 2001). As edited activities, he has co-edited four international books and co-edited 16 special issues in international journals on different Soft Computing topics.

He currently serves as area editor of the Journal Soft Computing (area of genetic algorithms and genetic fuzzy systems), and he serves as member of the editorial board of the journals: Fuzzy Sets and Systems, International Journal of Hybrid Intelligent Systems, International Journal of Computational Intelligence Research, Mediterranean Journal of Artificial Intelligence, International Journal of Information Technology and Intelligent Computing, Evolutionary Intelligence, and Memetic Computation. He acts as associated editor of the journals: Mathware and Soft Computing, Advances in Fuzzy Systems, and Advances in Computational Sciences and Technology.

His current research interests include computing with words and decision making, data mining and knowledge discovery, data preparation, fuzzy rule based systems, genetic fuzzy systems, knowledge extraction based on evolutionary algorithms, memetic algorithms and genetic algorithms.