

# Fuzzy Rule Reduction and Tuning of Fuzzy Logic Controllers for a HVAC System.\*

R. Alcalá, J. Alcalá-Fdez, M.J. Gacto, F. Herrera  
Dept. of Computer Science and Artificial Intelligence  
University of Granada, E-18071 – Granada, Spain  
e-mail: {alcala,jalcala,herrera}@decsai.ugr.es, mjgacto@ugr.es

## Abstract

Heating, Ventilating and Air Conditioning (HVAC) Systems are equipments usually implemented for maintaining satisfactory comfort conditions in buildings. The design of Fuzzy Logic Controllers for HVAC Systems is usually based on the operator's experience. However, an initial rule set drawn from the expert's experience sometimes fail to obtain satisfactory results, since inefficient or redundant rules are usually found in the final Rule Base. Moreover, in our case, the system being controlled is too complex and an optimal controller behavior is required.

Rule selection methods directly obtain a subset of rules from a given fuzzy rule set, removing inefficient and redundant rules and, thereby, enhancing the controller interpretability, robustness, flexibility and control capability. On the other hand, different parameter optimization techniques could be applied to improve the system accuracy by inducing a better cooperation among the rules composing the final Rule Base.

In this chapter, we present a study of how several tuning approaches can be applied and combined with a rule selection method to obtain more compact and accurate Fuzzy Logic Controllers concerning energy performance and indoor comfort requirements of a HVAC System. This study has been performed considering a physical modelization of a real test environment.

**Keywords:** HVAC systems, fuzzy logic controllers, rule selection, genetic tuning, genetic algorithms.

## 1 Introduction

HVAC Systems are equipments usually implemented for maintaining satisfactory comfort conditions in buildings. The energy consumption as well as indoor comfort aspects of ventilated and air conditioned buildings are highly dependent on the design, performance and control of their HVAC systems and equipments.

---

\*This research has been supported by the Spanish CICYT Project TIC-2002-04036-C05-01 (KEEL).

Therefore, the use of appropriate automatic control strategies, as fuzzy logic controllers (FLCs) [18, 38, 39], for HVAC systems control could result in important energy savings when compared to manual control, specially when they explicitly try to minimize the energy consumption [1, 5, 31, 43].

In current systems [5, 7, 22, 31, 37, 43, 44, 51, 52], various criteria are considered under separate cover, thermal regulation, maintaining a temperature set point or range, energy consumption, Predicted Mean Vote (PMV), system stability or indoor air quality. In Sections 2.2, include a deep explanation of this systems.

In this work, different criteria must be considered jointly in order to reduce the energy consumption maintaining a desired comfort level. In our case, five criteria will be optimized and 17 variables are considered by the FLC.

Control systems in buildings are often designed using rules of thumb not always compatible with the controlled equipment requirements and energy performance. Therefore, the different involved criteria should be optimized for a good performance of the HVAC System. A way to improve this problem is removing rules that degrade the system (rule selection method). On the other hand, other technique that improve performance of FLCs is tuning of parameters. There are two different tuning algorithms:

- *Classical tuning* : Consist of a tuning of the parameters that define the linguistic labels. We considered symmetrical fuzzy partitions of triangular-shaped membership functions, therefore three parameters are optimized.
- *Lateral tuning*: This technique is present in [4], with the result that reduces the size of the search space in complex problem. Moreover, this proposal decreases the tuning problem complexity, since the 3 parameters considered per label are reduced to only 1 symbolic translation parameter. As to how perform the lateral tuning there are two possibilities:
  - Global Tuning of the Semantics. Tuning is applied to the level of linguistic partition.
  - Local Tuning of the Rules. Tuning is applied to the level of rule.

In [3] presented a study of how smart combination of these basic techniques can improve furthermore the behavior of FRBS (system modeling with fuzzy rule-based system).

In this work, we propose combined different tuning methods (classic tuning and lateral tuning) with rules selection technique to obtain FLC more precise and compact concerning energy saving in HVAC System.

This contribution is arranged in the following way. In the next section, the basics of the HVAC systems control problem are presented, studying how FLCs can be applied to it. In Section 3, the proposed real test site and the control

objectives are introduced, establishing the concrete problem that will be solved in this work. In Sections 4, the use of rule selection are presented in depth. In Sections 5, show classic and lateral tuning methods considered in this work. Section 6 presents the evolutionary optimization process performing the rule selection together with the tuning methods. Experimental results are shown in Section 7. In Section 8, some concluding remarks are pointed out. Finally, a table with the used acronyms is presented in Appendix A.

## 2 Heating, Ventilating, and Air Conditioning Systems

An HVAC system is comprised by all the components of the appliance used to condition the indoor air of a building. The HVAC system is needed to provide the occupants with a comfortable and productive working environment which satisfies their physiological needs. Therefore, in a quiet and energy-efficient way at low life-cycle cost, an HVAC system should achieve two main tasks:

- To dilute and remove emission from people, equipment and activities and to supply clean air (Indoor Air Quality).
- To maintain a good thermal quality both in summer and winter (Thermal Climate).

There are no statistical data collected on types and sizes of HVAC systems delivered to each type of building in different European countries. Therefore, to provide an HVAC system compatible with the ambiance is a task of the BEMS designer depending on its own experience. In Figure 1, a typical office building HVAC system is presented. This system consists of a set of components to be able to raise and lower the temperature and relative humidity of the supply air.

### 2.1 The HVAC System Control Problem

Temperature and relative humidity are essential factors in meeting physiological requirements. When temperature is above or below the comfort range, the environment disrupts person's metabolic processes and disturbs his activities.

Therefore, an HVAC system is essential to a building in order to keep occupants comfortable. A well-designed operated, and maintained HVAC system is essential for a habitable and functional building environment. Outdated, inappropriate, or misapplied systems result in comfort complaints, indoor air quality issues, control problems, and exorbitant utility costs. Moreover, many HVAC systems do not maintain an uniform temperature throughout the structure because those systems employ unsophisticated control algorithms. In a modern intelligent

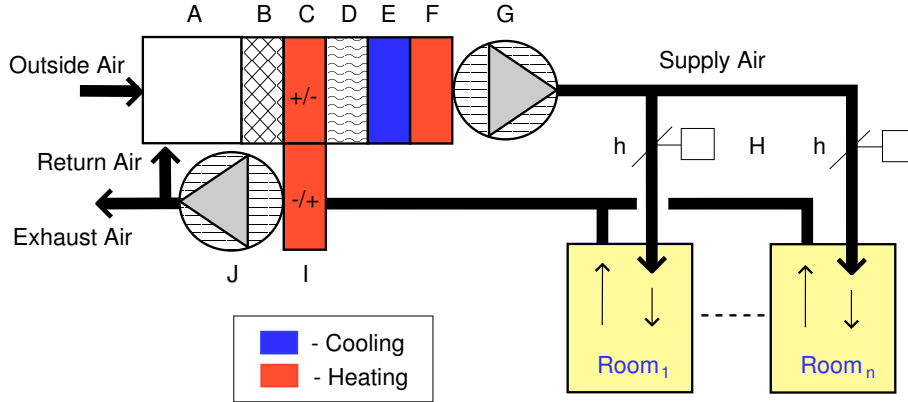

**A** - This module mixes the return and the outside air to provide supply air, and also closes outside air damper and opens return air damper when fan stops. **B** - It is a filter to reduce the outside air emissions to supply air. **C** - The preheater/heat recovery unit preheats the supply air and recovers energy from the exhaust air. **D** - A humidifier raising the relative humidity in winter. **E** - This is a cooler to reduce the supply air temperature and/or humidity. **F** - An after-heater unit to raise the supply air temperature after humidifier or to raise the supply air temperature after latent cooling (dehumidifier). **G** - The supply air fan. **H** - The dampers to demand controlled supply air flow to rooms. **I** - It is a heat recovery unit for energy recovery from exhaust air. **J** - The exhaust air fan.

Figure 1: Generic structure of an office building HVAC system

building, a sophisticated control system should provide excellent environmental control [5].

*Within this framework (building automation), the objective of a global controller is to maintain the indoor environment within the desired (or stipulated) limits. In our case, to maintain environmental conditions within the comfort zone and to control the indoor air quality. Furthermore, other important objectives are usually required, e.g, energy savings (our main objective), system stability, etc. In any case, numerous factors have to be considered in order to achieve these objectives. It makes the system being controlled very complex and present a strong non linearity.*

To obtain an optimal controller, control and controlled parameters <sup>1</sup> have to be chosen regarding the control strategy being implemented, the technical feasibility of the measurements as well as economic considerations. Fortunately, the BEMS designer is usually able to determine these parameters.

In the following subsections, the most usually used control and controlled

<sup>1</sup>Control or explicit parameters are variables which may be used as inputs or outputs for a control strategy (controller's variables), whilst controlled or implicit parameters are variables which are affected by the action of a controlled device, and may be considered in order to evaluate the performance of such controller (problem's objectives).

parameters are presented. The specific parameters considered in the test site (building) presented in this work will be selected among them in Section 3, where this site is introduced.

### 2.1.1 Control or explicit parameters: Controller's variables

To identify the FLC's variables, various (control or explicit) parameters may be considered depending on the HVAC system, sensors and actuators. Usually, these parameters are selected among the following ones:

- *Predicted Mean Vote (PMV) index for thermal comfort:* Instead of only using air temperature as a thermal comfort index, we could consider the more global PMV index selected by international standard organization ISO 7730 (<http://www.iso.org/iso/en/ISOOnline.frontpage>), incorporating relative humidity and mean radiant temperature.
- *Difference between supply and room temperatures:* Possible disturbances can be related to the difference between supply and mean air temperature. When ventilation systems are used for air conditioning, such a criterion can be important.
- *CO<sub>2</sub> concentration:* Indoor air quality was found to be critical. As CO<sub>2</sub> concentration is a reliable index of the pollution emitted by occupants, it can be selected as indoor air quality index. It is therefore supposed that both the building and the HVAC system have been properly designed and that occupants actually are the main source of pollution.
- *Outdoor temperature:* Outdoor temperature also needs to be accounted for, since during mid-season periods (or even mornings in summer periods) its cooling (or heating) potential through ventilation can be important and can reduce the necessity of applying mechanical cooling (or heating).
- *HVAC system actuators:* They directly depends on the concrete HVAC system, e.g., valve positions, operating modes, fan speeds, etc.

### 2.1.2 Controlled or implicit parameters: Problem's objectives

To identify global indices for assessment of the indoor building environment, various (controlled or implicit) parameters may be measured depending on the objectives of the control strategy. In these kinds of problems, these parameters could be selected among:

- *Thermal comfort parameters:* Indoor climate control is one of the most important goals of intelligent buildings. Among indoor climate characteristics, thermal comfort is of major importance. This might include both global and local comfort parameters.

- Indoor air quality parameters: Indoor air quality is also of major concern in modern buildings. It is controlled either at the design stage by reducing possible pollutants in the room and during operation thanks to the ventilation system. As our work is dedicated to HVAC systems, indoor air quality is also an important parameter to account for.
- Energy consumption: If appropriate indoor air quality and thermal comfort levels have to be guaranteed in offices, this has to be achieved at a minimum energy cost. Therefore, energy consumption parameters would need to be incorporated.
- HVAC system status: A stable operation of the controlled equipments is necessary in order to increase life cycle and thus reduce the maintenance cost. Information of the status of the equipments at the decision time step or on a longer period must thus be considered.
- Outdoor climate parameters: Indoor conditions are influenced by outdoor conditions (air temperature, solar radiation, wind). Moreover, in an air distribution HVAC system, the power required to raise or lower the supply temperature is a function of outdoor temperature and humidity. Some of these parameters would thus need to be selected.

## 2.2 Fuzzy Control of HVAC Systems

Nowadays, there is a lot of real-world applications of FLCs like intelligent suspension systems, mobile robot navigation, wind energy converter control, air conditioning controllers, video and photograph camera autofocus and imaging stabilizer, anti-sway control for cranes, and many industrial automation applications [30].

An FLC [18, 38, 39] is a kind of fuzzy rule-based system which is composed of a *KB* that comprises the information used by the expert operator in the form of linguistic control rules, a *Fuzzification Interface*, that transforms the crisp values of the input variables into fuzzy sets that will be used in the fuzzy inference process, an *Inference System* that uses the fuzzy values from the fuzzification interface and the information from the KB performing the reasoning process, and a *Defuzzification Interface*, which takes the fuzzy control action from the inference process and translates it into crisp values for the control variables. The KB is comprised of two components: the Data Base and the Rule Base. The Data Base contains the definitions of the linguistic labels, that is, the membership functions for the fuzzy sets. The Rule Base is a collection of fuzzy control rules, comprised by the linguistic labels, representing the expert knowledge of the controlled system. Figure 2 shows the generic structure of an FLC.

In current systems, various criteria are considered independently, thermal regulation, maintaining a temperature setpoint or range, which only considers

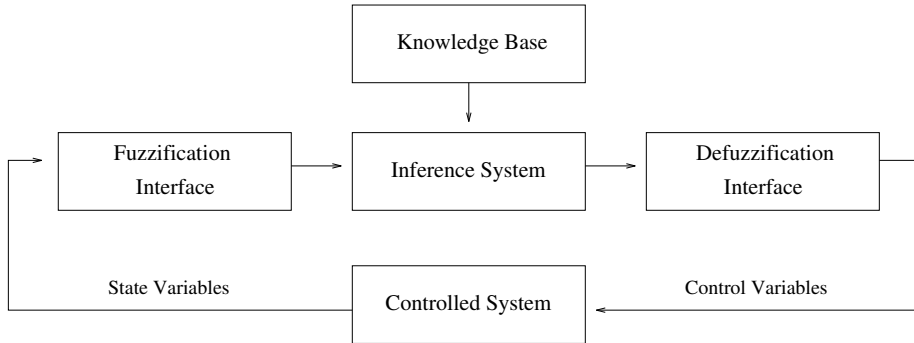

Figure 2: Generic structure of a FLC

implicit energy savings [5, 22, 31, 44, 51, 52]. In [7], the more global Predicted Mean Vote (PMV) is used to control thermal comfort (incorporating relative humidity and mean radiant temperature), but again it does not explicitly optimize the energy consumption, the system stability or the indoor air quality (CO<sub>2</sub> concentration). In [37], an adaptive neuro-fuzzy inference system (ANFIS) is employed to optimization of the system energy consumption by the control in-building section of HVAC system(indoor air loop and chilled water loop). In [43], a FLC involving 7 variables (5 inputs and 2 outputs) is optimized by means of an evolutionary algorithm to decrement the energy consumption and to maintain a temperature setpoint, which also set aside some important criteria.

However, in this work, various different criteria must be considered in order to reduce the energy consumption maintaining a desired comfort level. Therefore, many variables have to be considered from the controlled system, which makes the problem very complex. In our case, five criteria will be optimized and 17 variables are considered by the FLC.

In these kinds of problems (HVAC system controller design), the KB is usually constructed based on the operator’s experience. However, FLCs sometimes fail to obtain satisfactory results with the initial rule set drawn from the expert’s experience [31]. Moreover, in our case the system being controlled is too complex and optimal FLCs are required. Therefore, this approach needs of a modification of the initial KB to obtain an optimal controller with an improved performance.

A possible way to improve the FLC performance without losing interpretability to a high degree is to extend its usual structure making it more flexible. Many different possibilities to improve Linguistic Fuzzy Modeling have been considered in the specialized literature [8]. They can also be applied to the framework of fuzzy control (e.g., a tuning on the semantic of an FLC previously obtained from human experience could be performed by modification of the Data Base components [1, 2]). All of these approaches share the common idea of improving the way in which the linguistic fuzzy model/controller performs the interpolative reasoning by inducing a better cooperation between the rules in the KB.

There are two of these approaches presenting complementary characteristics, the parameter tuning and the rule selection. In this work, the combination of the tuning methods (classic and lateral tuning) with rule selection methods can present a positive synergy, reducing the search space, easing the system readability and even improving the system accuracy.

On the other hand, to evaluate the FLC performance, physical modelization of the controlled buildings and equipments is usually needed. These models have been developed by BEMS designers using building simulation tools, and they are able to account for all the parameters considered in the control process. Thus, we will have the chance to evaluate the FLCs designed in the simulated system with the desired environmental conditions. In the same way, these system models can be used by the experts to validate the initial KB before the automatic optimization process. Besides, it is of major importance to assess the fitness function in this process.

### 3 The GENESYS Test Cell

Within the framework of the JOULE-THERMIE programme under the GENESYS<sup>2</sup> project, a real test site (building) provided by a French private enterprise —whose name must remain anonymous— was available for experimentation. From now on, this site will be called the GENESYS test site.

Located in France, this test environment consists of seven single zone test cells. Around the walls of these cells, an artificial climate can be created at any time (winter conditions can be simulated in summer and *viceversa*). The cells considered are medium weight constructions. Figure 3 illustrates this environment and presents its main characteristics. Two adjacent twin cells were available for our experiments, the cells number four and five. Both test cells were equipped with all sensors required according to the selected control and controlled parameters. The HVAC system tested was a fan coil unit supplied by a reverse-cycle heat pump, and a variable fan speed mechanical extract for ventilation.

The first task was to develop the thermal model of this test site. The main achievement was the development of a full monozone building model. This model was built from scratch within the Matlab-Simulink environment, being developed as a general purpose model which could be used for any other conditions, projects or applications in the future. However, in order to improve its performance, it was later customized to suit the GENESYS test site. The thermal simulation was based on finite-differences methods for the conduction model. The maximum value for the time-step of the simulation was calculated using the stability condition according to the discretization scheme. Simulation time step could be

---

<sup>2</sup>GENESYS Project: Fuzzy controllers and smart tuning techniques for energy efficiency and overall performance of HVAC systems in buildings, European Commission, Directorate-General XII for Energy (contract JOE-CT98-0090).



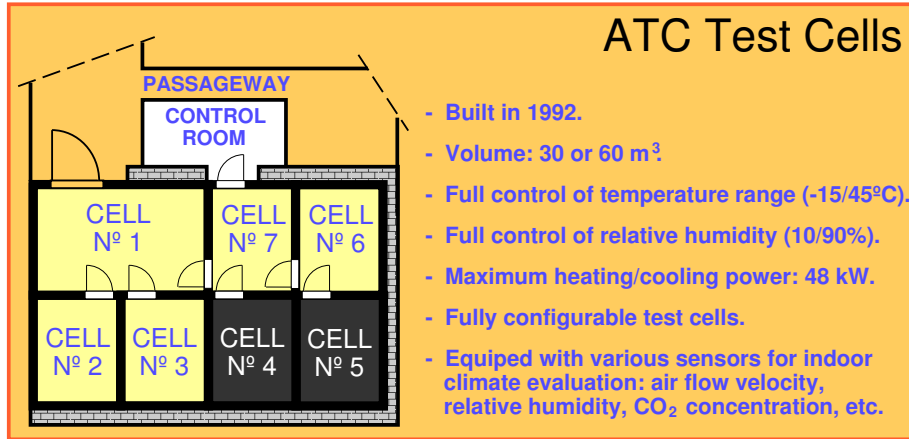

Figure 3: Representation and main characteristics of the GENESYS test cells

reduced to 60 seconds. Due to the relatively small thickness and large thermal conductivity of windows, the heat conduction model for the windows was considered constant. Convective heat exchanges were based on constant heat convection coefficients. Radiant temperature was calculated as a function of surface temperature, weighted by their relative area. The HVAC system model was based on manufacturers data and modules developed in the frame of *IEA (International Energy Agency) task 22* provided by the Royal Technical Institute of Stockholm.

Data were available and used for model calibration. The main problems in the calibration concerned the modelization of the HVAC equipment as well as solar radiation effects on internal heat gains. *The experimentation of this work has been performed considering the calibrated and validated GENESYS test cell simulation model.* Concretely, the GENESYS summer-season model.

### 3.1 Objectives and Fitness Function

As said, our main optimization objective was the energy performance but maintaining the required indoor comfort levels. Therefore, we should consider the development of a fitness function aiming at characterizing the performance of each tested controller towards thermal comfort, indoor air quality, energy consumption and system stability criteria. In this way, the global objective is to **minimize** the following five criteria:

$$O_1 \text{ Upper thermal comfort limit: } \textit{if } PMV > 0.5, O_1 = O_1 + (PMV - 0.5).$$

$$O_2 \text{ Lower thermal comfort limit: } \textit{if } PMV < -0.5, O_2 = O_2 + (-PMV - 0.5).$$

$$O_3 \text{ IAQ requirement: } \textit{if } CO_2 \textit{ conc. } > 800ppm, O_3 = O_3 + (CO_2 - 800).$$

$$O_4 \text{ Energy consumption: } O_4 = O_4 + \text{Power at time } t.$$

$O_5$  System stability:  $O_5 = O_5 +$  System change from time  $t$  to  $(t - 1)$ , where system change states for a change in the system operation, i.e., it counts the system operation changes (a change in the fan speed or valve position).

In our case, these criteria are combined into one overall objective function by means of a vector of weights. This technique (objective weighting) has much sensitivity and dependency toward weights. However, when trustworthy weights are available, this approach reduces the size of the search space providing the adequate direction into the solution space and its use is highly recommended. Since trustworthy weights were obtained from experts, we followed this approach.

Hence, an important outcome was to assign appropriate weights to each criterion of the fitness function. The basic idea in this weight definition was to find financial equivalents for all of them. Such equivalences are difficult to define and there is a lack of confident data on this topic. Whereas energy consumption cost is easy to set, comfort criteria are more difficult. Recent studies have shown that a 18% improvement in people's satisfaction about indoor climate corresponds to a 3% productivity improvement for office workers. Based on typical salaries and due to the fact that  $PMV$  and  $CO_2$  concentrations are related to people's satisfaction, such equivalences can be defined. The same strategy can be applied to the systems stability criterion, life-cycle of various systems being related to number of operations. Based on this, weights can be obtained for each specific building (test site). Thus, trusted weights for the GENESYS test cell objective weighting fitness function were obtained by the experts with the following values:  $w_1^O = 0.0083022$ ,  $w_2^O = 0.0083022$ ,  $w_3^O = 0.00000456662$ ,  $w_4^O = 0.0000017832$  and  $w_5^O = 0.000761667$ . Finally, the fitness function to be minimized was computed as:

$$F = \sum_{i=1}^n w_i^O \cdot O_i .$$

### 3.2 FLC Variables and Architecture

A hierarchical FLC architecture considering the  $PMV$ ,  $CO_2$  concentration, previous HVAC system status and outdoor temperature was proposed by the BEMS designer for this site. The GENESYS summer-season FLC architecture, variables and initial Rule Base are presented in Figure 4.

As Data Base, we considered symmetrical fuzzy partitions of triangular-shaped membership functions for each variable. These membership functions were labeled from  $L1$  to  $Ll_i$ , with  $l_i$  being the number of membership functions of the  $i$ -th variable. Figure 5 depicts the Data Base. Both, the initial Rule Base and the Data Base, were provided by the BEMS designer.

Notice that, Figure 4 represents the decision tables of each module of the hierarchical FLC considered in terms of these labels. When the Rule Base considers more than two input variables (as in the case of modules M-2 in layer 2 and

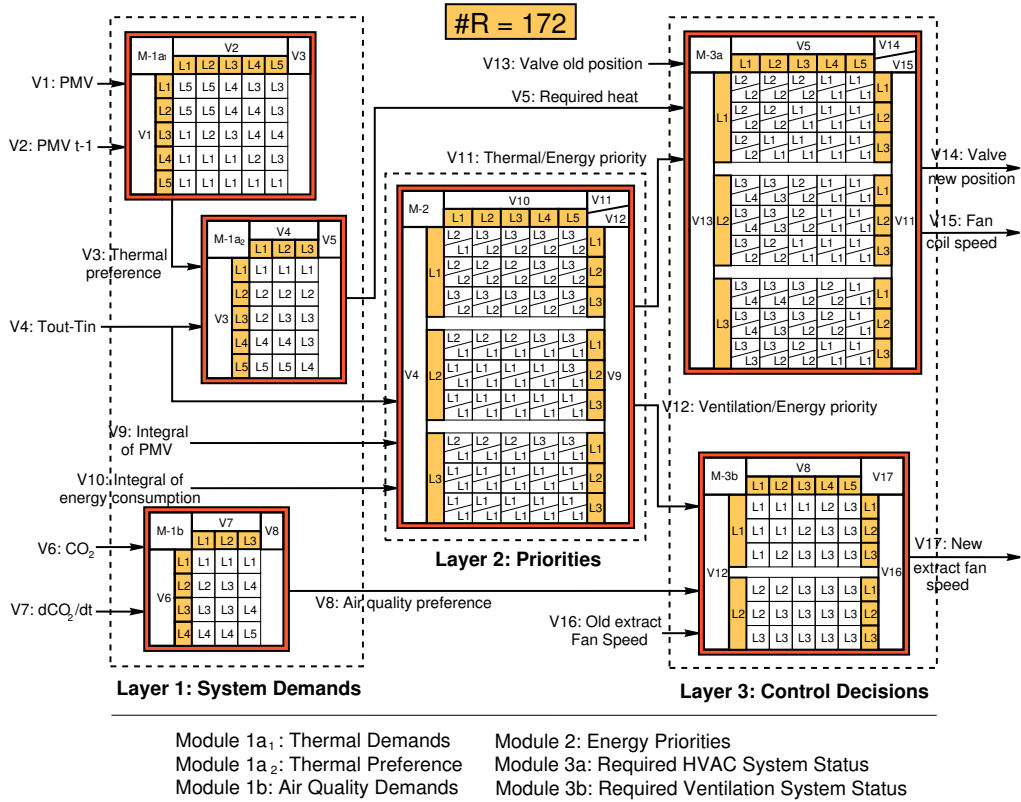

Figure 4: Initial Rule Base and generic structure of the GENESYS summer-season FLC

M-3a and M-3b in layer 3 where three input variables are involved), the three-dimensional table is decomposed into three two-dimensional decision tables (one for each possible label of the first variable) in order to clearly show its composition. Therefore, each cell of the table represents a fuzzy subspace and contains its associated output consequent(s), i.e., the corresponding label(s). The output variables are denoted in the top left square for each module. Notice that, when there are two consequents, they are placed in the same cell (divided by a diagonal line).

## 4 Rule Selection

In complex multidimensional problems with highly nonlinear input-output relations many redundant, inconsistent and conflicting rules are usually found in the obtained Rule Base (especially in the case when they are generated by only considering the expert's knowledge). On the other hand, in high-dimensional problems, the number of rules in the Rule Base grows exponentially as more in-

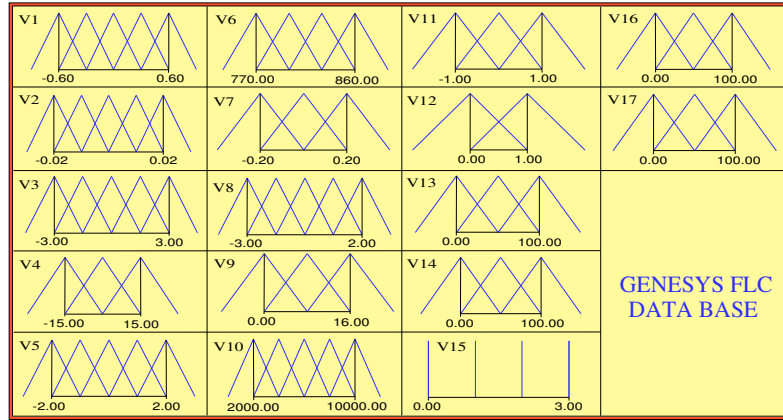

Figure 5: Data Base of the GENESYS summer-season fuzzy logic controller

puts are added. A large rule set might contain many redundant, inconsistent and conflicting rules. These kinds of rules are detrimental to the FLC performance and interpretability.

*Rule Selection* methods directly aggregate multiple rules and/or select a subset of rules from a given fuzzy rule set in order to minimize the number of rules while at the same time maintaining (or even improving) the system performance. Inconsistent and conflicting rules that degrade the performance are eliminated thus obtaining a fuzzy rule set with better cooperation.

Rule reduction methods have been formulated using Neural Networks, clustering techniques and orthogonal transformation methods, and algorithms based on similarity measures, among others [12, 25, 47, 48, 49, 53]. In [13], a different approach was proposed which attempts to reduce the growth of the Rule Base by transforming elemental fuzzy rules into DNF-form.

On the other hand, using GAs to search for an optimized subset of rules is motivated in the following situations:

- the integration of an expert rule set and a set of fuzzy rules extracted by means of automated learning methods [27],
- the selection of a cooperative set of rules from a candidate fuzzy rule set [14, 16, 15, 32, 33, 36],
- the selection of rules from a given KB together with the selection of the appropriate labels for the consequent variables [11],
- the selection of rules together with the tuning of membership functions by coding all of them (rules and parameters) in a chromosome [23], and

- the derivation of compact fuzzy models through complexity reduction combining fuzzy clustering, rule reduction by orthogonal techniques, similarity driving simplification and genetic optimization [45].

Two of them are of particular interest in our case, the second and the fourth. In this work, we propose the selection of a cooperative set of rules from a candidate fuzzy rule set together with tuning methods coding all in a chromosome. This pursues the following aims:

- To improve the FLC accuracy selecting the set of rules best cooperating while a local tuning of rules is performed to improve the interaction among them.
- To obtain simpler, and thus easily understandable, FLCs by removing unnecessary rules.

## 5 Tuning methods

In the next subsection, presented the classical and lateral tuning methods that improve performance of FLCs.

### 5.1 Classical Tuning of Fuzzy Rule-Based Systems

This approach, usually called data base tuning, involves refining the membership function shapes from a previous definition once the remaining FRBS components have been obtained [14, 24, 28, 34, 35, 40].

The classical way to refine the membership functions is to change their definition parameters. For example, if the following triangular-shape membership function is considered:

$$\mu(x) = \begin{cases} \frac{x-a}{b-a}, & \text{if } a \leq x < b \\ \frac{c-x}{c-b}, & \text{if } b \leq x \leq c \\ 0, & \text{otherwise} \end{cases} ,$$

changing the basic parameters —  $a$ ,  $b$ , and  $c$  — will vary the shape of the fuzzy set associated to the membership function, thus influencing the FRBS performance (See Figure 6). The same yields for other shapes of membership functions (trapezoidal, gaussian, sigmoid, etc.).

Tuning membership functions involves fitting the characterization of the membership functions associated to the primary linguistic terms considered in the system. Thus, the meaning of the linguistic terms is changed from a previous definition, an initial data base in an FRBS.

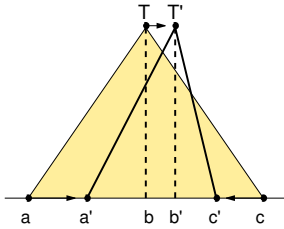

Figure 6: Tuning by changing the basic membership function parameters

In this way, in order to ensure a good interpretability through the membership functions optimization process [9, 41, 42], some researchers have proposed several properties. Considering one or more of these properties several constraints can be applied in the design process in order to obtain a BD, maintaining the linguistic model comprehensibility to the higher possible level [6, 14, 10, 21].

An example of evolutionary tuning can be seen in Figure 7, where each membership function is encoded by means of three gene values representing its definition points.

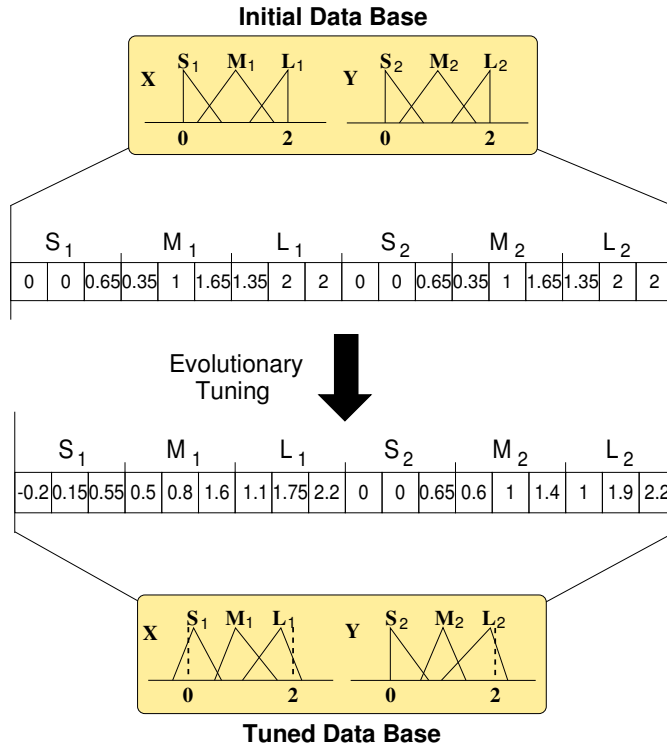

Figure 7: Example of evolutionary tuning

## 5.2 Lateral Tuning of Fuzzy Rule-Based Systems

In this section, we will introduce for the lateral tuning of fuzzy systems, presenting the rule structure and two different tuning approaches (global approach and local approach). Then, the evolutionary post-processing method to perform the lateral tuning following both approaches will be described.

### 5.3 The Lateral Tuning

The Lateral Tuning is a new model of tuning of FRBSs considering the linguistic 2-tuples representation to laterally tuning the support of a label, which maintains the interpretability associated to the representation model. In this way, the model for rule representation based on the linguistic 2-tuples is introduced. This concept is presented in [29] and allow a lateral displacement of the labels named symbolic translation.

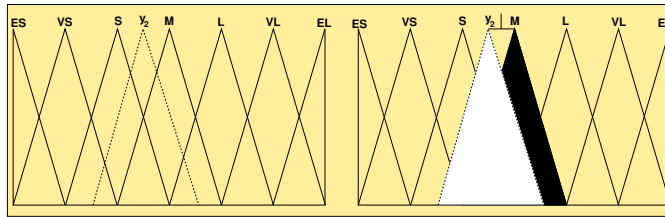

Figure 8: Lateral Displacement of the Linguistic Label M

Figure 8 shows the lateral displacement of the label M. The new label “ $y_2$ ” is located between B and M, being enough smaller than M but closer to M.

The symbolic translation of a linguistic term is a number within the interval  $[-0.5, 0.5]$  that expresses the domain of a label when it is moving between its two lateral labels. Formally, we have the couple,

$$(s_i, \alpha_i), \quad s_i \in S, \quad \alpha_i \in [0.5, -0.5].$$

Figure 9 depicts the symbolic translation represented by the couple  $(S_2, -0.3)$  considering a set  $S$  with five linguistic terms and representing the labels by their ordinal value in the said set  $\{0, 1, 2, 3, 4\}$ .

In [29], both the linguistic 2-tuples representation model and the needed elements for linguistic information comparison and aggregation are presented and applied to the Decision Making framework. In the context of the FRBSs, we are going to see its use in the linguistic rule representation. In the next we present this approach considering a simple control problem.

Let us consider a control problem with two input variables, one output variable and a DB defined from experts determining the membership functions for the following labels:

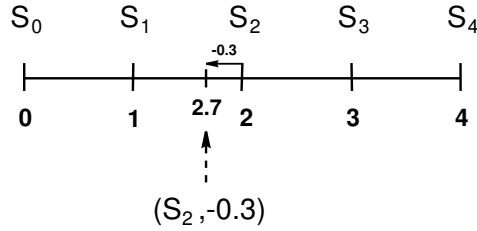

Figure 9: Symbolic translation of a label

$$Error \rightarrow \{N, Z, P\}, \quad \nabla Error \rightarrow \{N, Z, P\},$$

$$Power \rightarrow \{L, M, H\} .$$

**Classical Rule:**  
R1: If the **Error** is Zero and the **Error Variation** is Positive then the **Power** is High

**Rules with 2-tuples Representation:**  
R1: If the **Error** is (Zero, 0.3) and the **Error Variation** is (Positive, -0.2) then the **Power** is (High, -0.1)

Figure 10: Classical Rule and Rule with 2-Tuple Representation

Figure 10 shows the concept of classical rule and linguistic 2-tuples represented rule. Analyzed from the rule interpretability point of view, we could interpret the tuned rule as:

If the **Error** is “higher than Zero” and the **Error Variation** is “a little smaller than Positive” then the **Power** is “a bit smaller than High”.

This proposal decreases the tuning problem complexity, since the 3 parameters considered per label are reduced to only 1 symbolic translation parameter. As to how perform the lateral tuning there are two possibilities, the most interpretable one and the most accurate one:

- Global Tuning of the Semantics. In this case, the tuning is applied to the level of linguistic partition. In this way, the couple  $(X_i, \text{label})$  takes the same tuning value in all the rules where it is considered. For example,  $X_i$  is (High, 0.3) will present the same value for those rules in which the couple ”  $X_i$  is High” is initially considered.



Considering this approach, the global interpretability of the final FRBS is maintained. It is analogous to the classical tuning of the DB considering descriptive fuzzy rules [14], i.e., a global collection of fuzzy sets is considered by all the fuzzy rules. Therefore, this approach obtains more interpretable but less accurate linguistic models than the local approach.

- **Local Tuning of the Rules.** In this case, the tuning is applied to the level of rule. The couple  $(X_i, \text{label})$  is tuned in a different way in each rule, based on the quality measures associated to the tuning method (usually the system error).

Rule k:  $X_i$  is (High, 0.3) (more than high)

Rule j:  $X_i$  is (High, -0.2) (a little lower than high)

In this case, the global interpretability is lost to some degree and, the obtained model should be interpreted from a local point of view. This approach is analogous to the classical tuning of approximate fuzzy rules [14], i.e., each fuzzy rule has associated its own local fuzzy sets. However, in our case, the tuned labels are still related to the initial ones, preserving the global interpretability to some degree. Anyway, this approach presents more accuracy but less interpretability than the global approach.

Once both approaches have been presented, some aspects related to the search space reduction and the interpretability of the obtained models should be clarified. Naturally, these aspects are highly related to the kind of tuning performed (local or global).

We have pointed out that the lateral tuning decreases the tuning problem complexity, since only 1 symbolic translation parameter is considered per label. We must clarify that this is true individually considering both approaches, local and global. Therefore, the global lateral tuning reduces the search space respect to the classical tuning of the DB and the local lateral tuning reduces the search space respect to the classical tuning of approximate fuzzy rules. From the point of view of the interpretability, they also should be individually compared, since the global approach tries to obtain more interpretable models and the local approach tries to obtain more accurate ones.

## 6 Five Different Optimization Methods

Once the rule selection and two different tuning approaches has been presented, in this section, the genetic optimization algorithms developed for classical tuning

[24, 28], lateral tuning [4], rule selection [32, 46] and, the combined action of rule selection with both tuning approaches (rule selection and classical tuning, rule selection and lateral tuning) are proposed. However, only three of them will be presented, the first one, the second one and the last one, since the remaining can be respectively obtained as a part of this last (the  $C_T$  and the  $C_S$  parts).

In the following, the common parts of the said algorithm are introduced to later present its application to classical and lateral tuning methods and the combined action of rule selection with both tuning approaches (coding scheme and operators).

## 6.1 Common aspect of the algorithm

As said, it consists of a GA based on the well-known steady-state approach and considering an objective weighting-based fitness function. The steady-state approach [50] consists of selecting two of the best individuals in the population and combining them to obtain two offspring. These two new individuals are included in the population replacing the two worst individuals if the former are better adapted than the latter. An advantage of this technique is that good solutions are used as soon as they are available. Therefore, the convergence is accelerated while the number of evaluations needed is decreased (in our case it is very important since the model evaluation takes several minutes).

In order to make the method robust and more independent from the weight selection for the fitness function, the use of fuzzy goals for dynamically adapting the search direction in the space of solutions will be considered. The selection scheme is based on the Baker's stochastic universal sampling together with an elitist selection.

**Evaluating the chromosome:** The fitness function (see Section 3.1) has been modified in order to consider the use of fuzzy goals that decrement the importance of each individual fitness value whenever it comes to its respective goal or penalize each objective whenever its value worse with respect to the initial solution. To do so, a function modifier parameter is considered,  $\delta_i(x)$  (taking values over 1.0). A penalization rate,  $p_i$ , has been included in  $\delta_i(x)$ , allowing the user to set up priorities in the objectives (0 less priority and 1 more priority). Therefore, the global fitness is evaluated as:

$$F' = \sum_{i=1}^5 w_i^O \cdot \delta_i(O_i) \cdot O_i \ ,$$

Two situations can be presented according to the value of the goal  $g_i$ , and the value of the initial solution  $i_i$ . Depending on these values, two different  $\delta$  functions will be applied:

- When the value of  $g_i$  is lesser than the value of  $i_i$ , the objective is not considered if the goal is met and penalized if the initial results are worsened (see Figure 11).

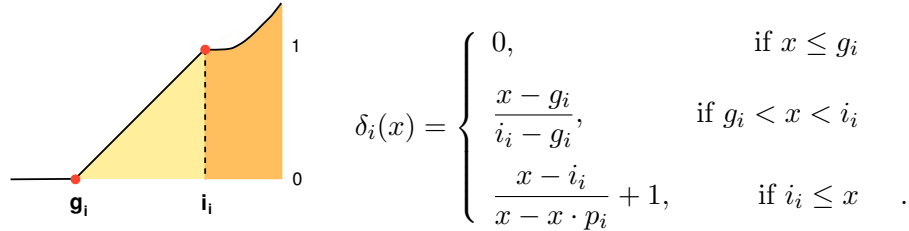

Figure 11:  $\delta_i(x)$  when  $g_i \leq i_i$

- When the value of  $i_i$  is lesser than the value of  $g_i$ , the initial results can be worsened while the goal is met and, it is penalized otherwise (see Figure 12).

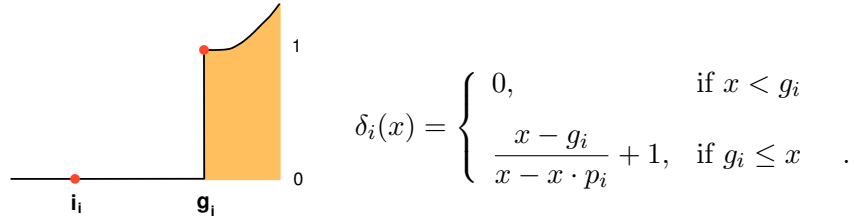

Figure 12:  $\delta_i(x)$  when  $g_i > i_i$

**Restart approach:** Finally, to get away from local optima, this algorithm uses a restart approach [19]. Thus, when the population of solutions converges to very similar results (practically the same fitness value in all the population), the entire population but the best individual is randomly generated within the corresponding variation intervals. It allows the algorithm to perform a better exploration of the search space and to avoid getting stuck at local optima.

## 6.2 Classical tuning

In this subsection, the coding scheme and genetic operators of the algorithm proposed for classical tuning are explained. To do so, the WMC-SSGA approach presented in [2], which is exactly the same that is considered for classical tuning, will be briefly described.

The coding scheme represents a solution by joining the representation of the  $l_i$  labels of each one of the  $n$  variables composing the DB:

$$C_i = (a_1^i, b_1^i, c_1^i, \dots, a_{l_i}^i, b_{l_i}^i, c_{l_i}^i), \quad i = 1, \dots, n \quad ,$$

$$C_T = C_1 C_2 \dots C_n \quad .$$

To make use of the existing knowledge, the DB previously obtained from experts is included in the population as an initial solution. The remaining individuals are randomly generated maintaining their genes within their respective variation intervals. These intervals are computed from the initial DB, having the same interval the group composed by the vertex of a label and the nearest points of the next and the previous labels. From these groups, the interval extremes are obtained computing the middle point between the nearest points of the corresponding consecutive groups [2]. Finally, these intervals are dynamically adapted from the best individual for each generation.

Since a real coding scheme is considered, the crossover and mutation operators have been selected according to this aspect: the Max-Min-Arithmetical crossover and Michale-wicz's non-uniform mutation (more complete information on these operators can be found in [2, 17]). Once the mutation operator is applied on the four offspring generated by the crossover operator, the two best are selected as the final descendents.

### 6.3 Lateral tuning

This subsection present the coding scheme and genetic operators of the lateral tuning algorithm.

#### Coding scheme and initial gene pool

Taking into account that two different types of tuning have been proposed (global tuning of the semantics and local tuning of the rules), there are two different kinds of coding schemes. In both cases, a real coding is considered, i.e., the real parameters are the GA representation units (genes).

In the following both schemes are presented:

- Global Tuning of the Semantics: Joint of the parameters of the fuzzy partitions. Let us consider the following number of labels per variable:  $(m^1, m^2, \dots, m^n)$ , with  $n$  being the number of system variables. Then, a chromosome has the following form (where each gene is associated to the tuning value of the corresponding label),

$$C_T = (c_{11}, \dots, c_{1m^1}, c_{21}, \dots, c_{2m^2}, \dots, c_{n1}, \dots, c_{nm^n}).$$

See the  $C_T$  part of Figure 13 (in the next section) for an example of coding scheme considering this approach.

- Local Tuning of the Rules: Joint of the rule parameters. Let us consider that the FRBS has  $M$  rules:  $(R1, R2, \dots, RM)$ , with  $n$  system variables. Then, the chromosome structure is,

$$C_T = (c_{11}, \dots, c_{1n}, c_{21}, \dots, c_{2n}, \dots, c_{M1}, \dots, c_{Mn}).$$

To make use of the available information, the initial FRBS obtained from automatic fuzzy rule learning methods or from expert's knowledge is included in the population as an initial solution. To do so, the initial pool is obtained with the first individual having all genes with value '0.0', and the remaining individuals generated at random.

## Genetic Operators

The genetic operator considered is crossover. No mutation is considered in this case in order to improve the algorithm convergence. A description of the crossover operator is presented in the following.

The BLX- $\alpha$  crossover [20] and a hybrid between a BLX- $\alpha$  and an arithmetical crossover [26] are considered. In this way, if two parents,  $C_T^v = (c_{T1}^v, \dots, c_{Tk}^v, \dots, c_{Tm}^v)$  and  $C_T^w = (c_{T1}^w, \dots, c_{Tk}^w, \dots, c_{Tm}^w)$ , are going to be crossed in  $C_T$ , two different crossovers are considered:

1. Using the BLX- $\alpha$  crossover [20] in the second parts (with  $\alpha$  being a constant parameter chosen by the GA designer), one descendent  $C_T^h = (c_{T1}^h, \dots, c_{Tk}^h, \dots, c_{Tm}^h)$  is obtained, with  $c_{Tk}^h$  being randomly generated within the interval  $[I_{L_k}, I_{R_k}] = [c_{min} - I \cdot \alpha, c_{max} + I \cdot \alpha]$ ,  $c_{min} = \min(c_{Tk}^v, c_{Tk}^w)$ ,  $c_{max} = \max(c_{Tk}^v, c_{Tk}^w)$  and  $I = c_{max} - c_{min}$ .
2. The application of the arithmetical crossover [26] in the wider interval considered by the BLX- $\alpha$ ,  $[I_{L_k}, I_{R_k}]$ , results in the next descendent:

$$C_T^h \text{ with } c_{Tk}^h = aI_{L_k} + (1 - a)I_{R_k},$$

with  $a \in [0, 1]$  being a random parameter generated each time this crossover operator is applied. In this way, this operator performs the same gradual adaptation in each gene, which is an interest characteristic.

## 6.4 Rule selection combine with tuning approaches

In this subsection, explain the coding scheme and genetic operators of the algorithm combining rule selection with tuning approaches.

### Coding scheme and initial gene pool

A double coding scheme ( $C = C_S + C_T$ ) for both *rule selection* and *tuning* is used:

- For the  $C_S$  part, the coding scheme generates binary-coded strings of length  $m$  (with  $m$  being the number of fuzzy rules in the existing FLC, obtained from expert knowledge). Depending on whether a rule is selected or not,

the alleles ‘1’ or ‘0’ will be respectively assigned to the corresponding gene. Thus, the corresponding part  $C_S^p$  for the  $p$ -th chromosome will be a binary vector representing the subset of rules finally obtained.

$$C_S^p = (c_{S1}^p, \dots, c_{Sm}^p) \mid c_{Si}^p \in \{0, 1\}$$

- The  $C_T$  part represent the coding scheme, previously explained, for the classical or lateral tuning algorithm.

Finally, a chromosome  $C^p$  is coded in the following way:

$$C^p = C_S^p C_T^p$$

To make use of the available information, the FLC previously obtained from expert knowledge is included in the population as an initial solution. To do so, the initial pool is obtained with an individual having all genes with value ‘1’ in  $C_S$  part and all genes with value ‘0.0’ in  $C_T$  part, and the remaining individuals generated at random:

$$\forall k \in \{1, \dots, m\}, c_{Sk}^1 = 1 \text{ and } c_{Tk}^1 = 0.0 .$$

## Genetic operators

The crossover operator will depend on the chromosome part where it is applied: in the  $C_S$  part, the standard two-point crossover is used, whilst in the  $C_T$  part for classical tuning is applied Max-Min-Arithmetical operator and for lateral tuning is applied a hybrid between a BLX- $\alpha$  and an arithmetical crossover.

The two-point crossover involves exchanging the fragments of the parents contained between two points selected at random (resulting two different descendents).

Finally, four offspring are generated by combining the two ones from the  $C_S$  part (two-point crossover) with the two ones from the  $C_T$  part.

As regards the mutation operator, it flips the gene value in the  $C_S$  part. In  $C_T$  part for classical tuning use Michale-wicz’s non-uniform mutation operator and for lateral tuning no mutation is applied. In this way, once the mutation operator is applied over the four offspring obtained from the crossover operator, the resulting descendents are the two best of these four individuals.

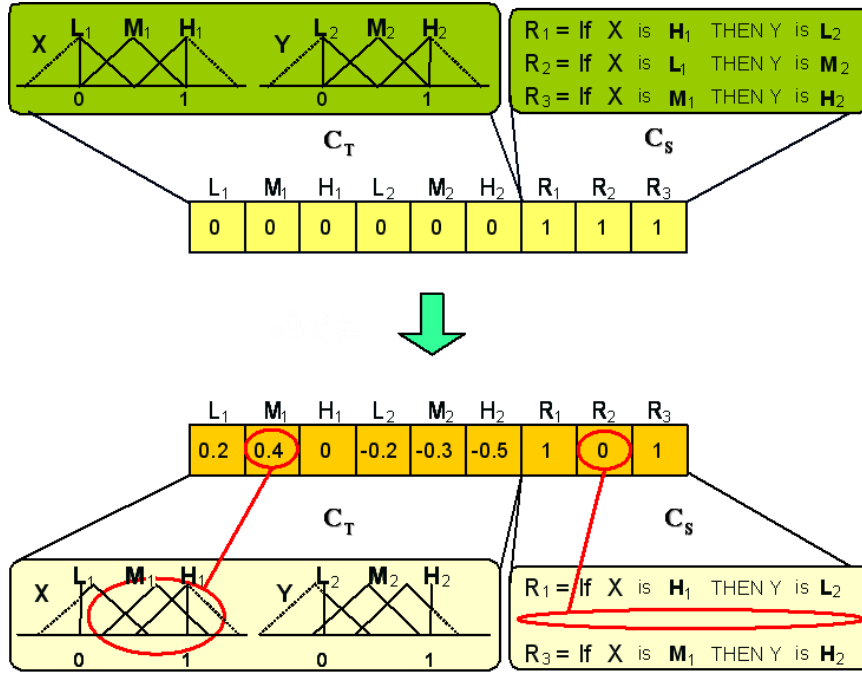

Figure 13: Example of Coding Scheme Considering the Global Tuning and Rule Selection

## 7 Experiments and Analysis of Results

To evaluate the goodness of the proposed technique, several experiments have been carried out considering the GENESYS test site. The main characteristics, the control objectives and the initial FLC for this site have been presented in Section 3. In this section, the experiments performed with the new weighted rules FLC on the said GENESYS summer model are presented. In order to see the advantages of the combined action of the rule selection and tuning techniques, three different studies have been performed:

1. *Considering the said post-processing approaches separately.* In this case, we consider the different proposed techniques individually:
  - Rule Selection.
  - Classical Tuning.
  - Lateral Tuning (both approaches, global and local).
2. *Combining the rule selection with the tuning approaches.* In this case, we consider the rule selection and the different tuning approaches jointly:
  - Rule Selection and Classical Tuning.
  - Rule Selection and Lateral Tuning (both approaches, global and local).

3. *Analysis of the approaches.* A comparison will be performed pointing out the good performance obtained when both, rule selection and tuning, are combined.

To assess the proposed techniques for fitness computation, accurate models of this controlled building (as well as the corresponding initial FLC) were provided by experts. The proposed optimization strategy was assessed with simulations of 10 days with the corresponding climatic conditions.

The FLCs obtained from the proposed technique will be compared to the performance of the initial expert FLC and to the performance of a classic On-Off controller. *The goals and improvements will be computed with respect to this classical controller as done in the GENESYS<sup>1</sup> project.* The intention from experts was to try to have 10% energy saving ( $O_4$ ) together with a global improvement of the system behavior compared to On-Off control. Comfort parameters could be slightly increased if necessary (no more than 1.0 for criteria  $O_1$  and  $O_2$ ).

Table 1: Initial results and fitness function ( $F'$ ) parameters

MODEL	#R	Fitness		PMV		CO <sub>2</sub> $O_3$	Energy		Stability	
		F	%	$O_1$	$O_2$		$O_4$	%	$O_5$	%
ON-OFF	—	6.58	—	0.0	0	0	3206400	—	1136	—
FLC	172	6.32	4	0.0	0	0	2901686	9.50	1505	-32.48
Goals ( $g_i$ )	—	—	—	1.0	1	7	2000000	—	1000	—
Rates ( $p_i$ )	—	—	—	1	1	1	0.9	—	0.97	—

Table 1 presents the results obtained with the On-Off and the initial FLC controllers together with the parameters considered to compute the fitness function in the GA ( $F'$ ), fuzzy goals and penalization rates (the objective weights can be seen in Section 3.1). Notice that, the goals imposed to the algorithm are higher than the ones initially required by the experts since we are trying to obtain even better results. No improvement percentages have been considered in the table for  $O_1 \dots O_3$ , since these objectives always met the experts requirements and the On-Off controller presents zero values for these objectives.

Finally, the values of the parameters used in all of these experiments are presented as follows: 31 individuals, 0.2 as mutation probability per chromosome (except for the Lateral Tuning which has no mutation), 0.3 for the factor  $\alpha$  in the hybrid crossover operator and 0.35 as factor  $a$  in the max-min-arithmetical crossover. The termination condition will be the development of a fixed number of iterations, which will depend on the approach (Classical Tuning, Lateral Tuning or Rule Selection with Tuning approaches) followed, in order to perform a fair comparative study as we will see as follows. In order to evaluate the GA good



convergence, three different runs have been performed considering three different seeds for the random number generator.

### 7.1 Results considering the said post-processing approaches separately

The models presented in Table 3, where % stands for the improvement rate with respect to the On-Off controller for each criterion and #R for the number of fuzzy rules, correspond to the best individuals from the population at 1000 or 500 iterations considering the three runs performed. Moreover, the averaged results have been presented for each criterion. The time required for each model evaluation is 215 seconds (for rule selection and lateral tuning) or 430 seconds (for classical tuning) approximately.

Table 2: Methods Considered for Comparison

Method	Description
<b>S</b>	Rule Selection
<b>C</b>	Classical Genetic Tuning
<b>GL</b>	Global Lateral Tuning
<b>LL</b>	Local Lateral Tuning

The models presented in Table 3 correspond to the best individuals from the population at iteration 500 (for the classical tuning) or 1000 (for the rule selection and the lateral tuning) considering the three proposed seeds. The estimated run time is four days for 500 or 1000 iterations (evaluations  $\times$  evaluation time  $\times$  generations).

From the obtained results, the tuning approaches present better result in energy and stability than the rule selection, On-Off controller and the initial FLC controller. The rule selection technique minimize the number of rules while at the same time significant little improvements over the On-Off controller, but not over tuning approaches.

Within the tuning approaches, the lateral tuning present a good trade-off between energy and stability, because this approaches reduces the size of the search space in complex problem, like our problem. Lateral techniques are robust and perform a better exploration of the search space and avoid getting stuck at local optima. Specifically, the local tuning approach obtain more accurate than the global approach, due to this technique present a best freedom degree and tuned each parameter locally. The local tuning presenting improvement rates of about a 26% in energy and about a 18% in stability.

Table 3: Results obtained with rule selection and tuning approaches

MODEL	#R	PMV		CO <sub>2</sub>	Energy		Stability	
		O <sub>1</sub>	O <sub>2</sub>	O <sub>3</sub>	O <sub>4</sub>	%	O <sub>5</sub>	%
ON-OFF	–	0.0	0	0	3206400	–	1136	–
FLC	172	0.0	0	0	2901686	9.50	1505	-32.48
Rule Selection								
S1	147	0.2	0	0	2867692	10.56	991	12.76
S2	162	0.0	0	0	2889889	9.87	1441	-26.85
S3	172	0.0	0	0	2901686	9.50	1505	-32.48
Classical Tuning								
C1	172	0.0	0	0	2575949	19.66	1115	1.85
C2	172	0.0	0	0	2587326	19.31	1077	5.19
C3	172	0.0	0	0	2596875	19.01	1051	7.48
Global Lateral Tuning								
GL1	172	0.7	0	0	2378784	25.81	1069	5.90
GL2	172	1.0	0	0	2327806	27.40	1066	6.16
GL3	172	0.9	0	0	2268689	29.25	1080	4.93
Local Lateral Tuning								
LL1	172	0.9	0	0	2386033	25.59	896	21.13
LL2	172	0.8	0	0	2343409	26.92	943	16.99
LL3	172	0.3	0	0	2377596	25.85	938	17.43

## 7.2 Results Combining the rule selection with the tuning approaches

The models presented in Table 5 correspond to the best individuals from the population at iteration 500 considering the three proposed seeds (once again % stands for the improvement rate with respect to the On-Off controller and #R for the number of fuzzy rules). Now, both parts, rule selection ( $C_S$ ) and tuning approaches ( $C_T$ ), are considered and four evaluations are required per iteration. In order to maintain the number of evaluations equal to the one considered in the previous subsection only 500 iterations will be considered. Therefore, the estimated run time was four days for 500 iterations (computed as product of the number of evaluations per generation, the evaluation time and the number of generations).

In view of the obtained results, we can point out that all the controllers derived by the proposed method achieve significant improvements over both, the On-Off controller and the initial FLC controller. In this case, all the goals required by experts were met, amply exceeding the expected results.

A good trade-off between energy and stability was achieved for all the ob-

Table 4: Methods Considered for Comparison

Method	Description
<b>C-S</b>	Classical Tuning and Rule Selection
<b>GL-S</b>	Global Lateral Tuning and Rule Selection
<b>LL-S</b>	Local Lateral Tuning and Rule Selection

Table 5: Results obtained combining rule selection with tuning approaches

MODEL	#R	PMV		CO <sub>2</sub>		Energy		Stability	
		O <sub>1</sub>	O <sub>2</sub>	O <sub>3</sub>	O <sub>4</sub>	%	O <sub>5</sub>	%	
ON-OFF	–	0.0	0	0	3206400	–	1136	–	
FLC	172	0.0	0	0	2901686	9.50	1505	-32.48	
Selection with Classical Tuning									
C-S1	94	0.0	0	0	2540065	20.78	1294	-13.91	
C-S2	109	0.1	0	0	2492462	22.27	989	12.94	
C-S3	100	0.1	0	0	2578019	19.60	887	21.92	
Selection with Global Lateral Tuning									
GL-S1	105	1.0	0	0	2218598	30.81	710	37.50	
GL-S2	115	0.4	0	0	2358405	26.45	818	27.99	
GL-S3	118	0.8	0	0	2286976	28.68	872	23.24	
Selection with Local Lateral Tuning									
LL-S1	133	0.5	0	0	2311986	27.90	788	30.63	
LL-S2	104	0.6	0	0	2388470	25.51	595	47.62	
LL-S3	93	0.5	0	0	2277807	28.96	1028	9.51	

tained models, maintaining the remaining criteria within the optimal values. GL-S presents improvement rates of about a 28.6% in energy and about a 29.6% in stability. Since the remaining criteria for comfort and air quality are within the requested levels. Moreover, the proposed algorithm presents a good convergence and seems to be independent of random factors.

Figure 14 represents the initial and the final data base for the genetic FLC taking as final DB the first solution for global tuning with selection in Table 5. It shows that small variations in the membership function parameters cause large improvements in the FLC performance.

Figure 15 represents the decision tables of the model obtained from GL-S considering the first seed (see Section 3.2). In this case, a large number of rules have been removed from the initial FLC, obtaining much simpler models (more or less 70 rules were eliminated in each run). This fact improves the system

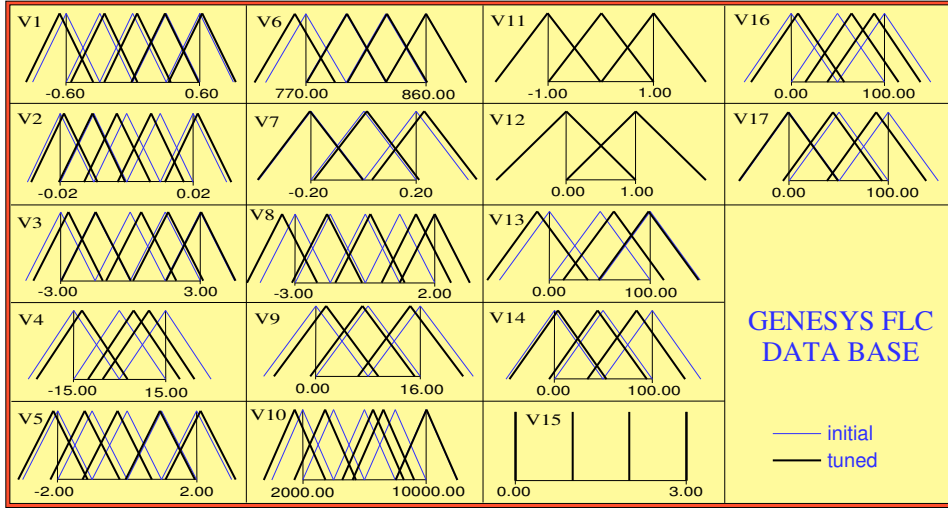

Figure 14: Genetic FLC

readability, and allows us to obtain simple and accurate FLCs.

### 7.3 Analyzing Both Approaches

In order to see how the consideration of the rule selection affects to the tuning approaches, Table 6 presents a comparison. The averaged results obtained from the three different runs performed in the previous subsections are shown in the table.

Table 6: Comparison among the different methods

MODEL	#R	PMV		CO <sub>2</sub>	Energy		Stability		
		O <sub>1</sub>	O <sub>2</sub>	O <sub>3</sub>	O <sub>4</sub>	%	O <sub>5</sub>	%	
ON-OFF	—	0.0	0	0	3206400	—	1136	—	
FLC	172	0.0	0	0	2901686	9.50	1505	-32.48	
Averaged Results									
$\bar{S}$	160	0.1	0	0	2886422	9.98	1312	-15.52	
$\bar{C}$	172	0.0	0	0	2586717	19.33	1081	4.84	
$\overline{GL}$	172	0.9	0	0	2325093	27.49	1072	5.66	
$\overline{LL}$	172	0.7	0	0	2369013	26.12	926	18.52	
$\overline{C - S}$	109	0.1	0	0	2536849	20.88	1057	6.98	
$\overline{GL - S}$	113	0.7	0	0	2287993	28.64	800	29.58	
$\overline{LL - S}$	110	0.5	0	0	2326088	27.46	804	29.26	

The methods combining the rule selection with the tuning approaches has

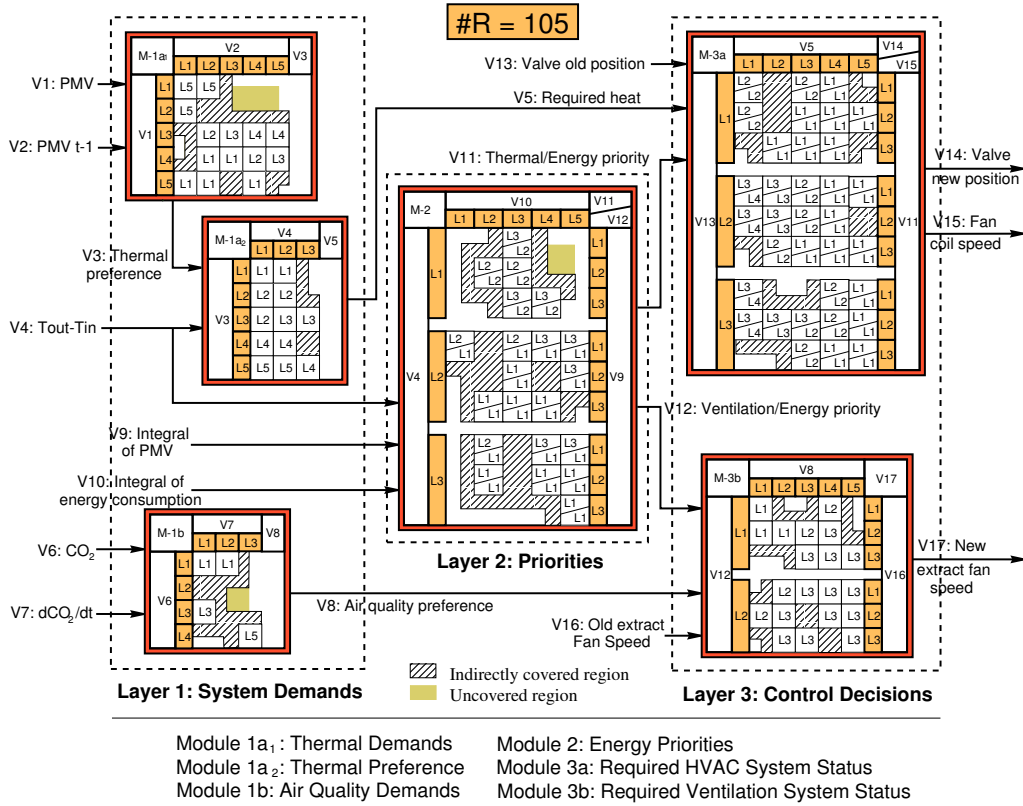

Figure 15: Global lateral tuning and rule selection Rule Base and final structure of the GENESYS summer-season FLC (seed 1)

yielded much better results than post-processing approaches separately, showing the good results that the global lateral tuning together with a rule selection in this problem. Moreover, since the initial rules and membership functions remains fixed, the interpretability level obtained is very near to the original one.

It is notorious the fact that the simplified FLCs present much better results that the ones obtained by only tuning approaches. The simplified FLCs only maintain a 64% of the initial rules. On the other hand, considering rule selection helps to reducing the search space and favor the ability of such technique to obtain good solutions.

Analyzing the results presented in Table 6 we can point out the following conclusions:

- The global lateral tuning improvement of the system behavior in optimization of the energy consumption, particularly when this approach is combined with rule selection.

- Combining the local lateral tuning with rule selection obtain a model with high stability level maintaining a high level of energy savings.
- The lateral tuning methods with rule selection allow to removing inefficient and redundant rules with the tuning of parameters, obtaining results with high percentage of energy and stability savings.

## 8 Concluding Remarks

In this work, we propose the use of tuning approaches together with a rule selection to develop accurate FLCs dedicated to the control of HVAC systems concerning energy performance and indoor comfort requirements. To do so, a GA considering an efficient approach to perform tuning approaches and rule selection has been developed.

The proposed technique has yielded much better results than the classical On-Off controller showing its good behavior on these kinds of complex problems. It is due to the following reasons:

- The lateral tuning reduce the search space in complex problem. These approaches offers a great improvement of the system accuracy and obtain an interpretable model.
- The complementary characteristics that the use of tuning approaches and the rule selection approach present. The ability of rule selection reduce number of rules by only selecting the rules presenting a good cooperation is combined with tuning approaches.

## A Acronyms

Acronym	Meaning
<i>BEMS</i>	<i>Building Energy Management System</i>
<i>FLC</i>	<i>Fuzzy Logic Controller</i>
<i>FRBS</i>	<i>System modeling with fuzzy rule-based system</i>
<i>GA</i>	<i>Genetic Algorithm</i>
<i>HVAC</i>	<i>Heating, Ventilating, and Air Conditioning</i>
<i>KB</i>	<i>Knowledge Base</i>
<i>PMV</i>	<i>Predicted Mean Vote index for thermal comfort</i>

## Acknowledgements

We would like to thank the GENESYS <sup>1</sup> project partners for their careful implementation of the presented HVAC simulation models and for their valuable assistance.

## References

- [1] R. Alcalá, J. Casillas, J.L. Castro, A. González, F. Herrera, A multicriteria genetic tuning for fuzzy logic controllers, *Mathware and Soft Computing* 8:2 (2001) 179–201.
- [2] R. Alcalá, J.M. Benítez, J. Casillas, O. Cordón, R. Pérez, Fuzzy control of HVAC systems optimized by genetic algorithms, *Applied Intelligence* 18 (2003) 155–177.
- [3] R. Alcalá, J. Alcalá-Fdez, J. Casillas, O. Cordón, F. Herrera, Hybrid Learning Models to Get the Interpretability-Accuracy Trade-Off in Fuzzy Modeling, *International Journal of Soft Computing* (2004) in press.
- [4] R. Alcalá, F. Herrera, Genetic tuning on fuzzy systems based on the linguistic 2-tuples representation, in *Proc. of the 2004 IEEE International Conference on Fuzzy Systems 1* (Budapest, Hungary, 2004) 233–238.
- [5] M. Arima, E.H. Hara, J.D. Katzberg, A fuzzy logic and rough sets controller for HVAC systems, *Proceedings of the IEEE WESCANEX'95 1* (NY, 1995) 133–138.
- [6] U. Bodenhofer and P. Bauer, A formal model of interpretability of linguistic variables, in *Interpretability issues in fuzzy modeling*, J. Casillas, O. Cordón, F. Herrera, L. Magdalena (Eds.), Springer-Verlag (2003) 524–545.
- [7] F. Calvino, M.L. Gennusa, G. Rizzo, G. Scaccianoce, The control of indoor thermal comfort conditions: introducing a fuzzy adaptive controller, *Energy and Buildings* 36 (2004) 97–102.
- [8] J. Casillas, O. Cordón, F. Herrera, L. Magdalena (Eds.), *Accuracy improvements in linguistic fuzzy modeling*, *Studies in Fuzziness and Soft Computing* 129 (Springer-Verlag, Heidelberg, Germany, 2002).
- [9] J. Casillas, O. Cordón, F. Herrera, L. Magdalena (Eds.), *Interpretability issues in fuzzy modeling*, Springer-Verlag (2003).
- [10] F. Cheong and R. Lai, Constraining the optimization of a fuzzy logic controller using an enhanced genetic algorithm, *IEEE Trans. Syst., Man, Cybern.*
- [11] T. C. Chin, X. M. Qi, Genetic algorithms for learning the rule base of fuzzy logic controller, *Fuzzy Sets and Systems* 97:1 (1998) 1–7.
- [12] S. Chiu, Fuzzy model identification based on cluster estimation, *Journal of Intelligent and Fuzzy Systems* 2 (1994) 267–278.

- [13] W. E. Combs, J. E. Andrews, Combinatorial rule explosion eliminated by a fuzzy rule configuration, *IEEE Transactions on Fuzzy Systems* 6:1 (1998) 1–11.
- [14] O. Cordón, F. Herrera, A three-stage evolutionary process for learning descriptive and approximative fuzzy logic controller knowledge bases from examples, *International Journal of Approximate Reasoning* 17:4 (1997) 369–407.
- [15] O. Cordón, M. J. del Jesús, F. Herrera, Genetic learning of fuzzy rule-based classification systems cooperating with fuzzy reasoning methods, *International Journal of Intelligent Systems* 13:10-11 (1998) 1025–1053.
- [16] O. Cordón, F. Herrera, A proposal for improving the accuracy of linguistic modeling, *IEEE Transaction on Fuzzy Systems* 8:3 (2000) 335–344.
- [17] O. Cordón, F. Herrera, F. Hoffmann, and L. Magdalena, *Genetic fuzzy systems—evolutionary tuning and learning of fuzzy knowledge bases*, World Scientific (2001).
- [18] D. Driankov, H. Hellendoorn, M. Reinfrank, *An introduction to fuzzy control* (Springer-Verlag, 1993).
- [19] L.J. Eshelman, The CHC adaptive search algorithm: How to have safe search when engaging in nontraditional genetic recombination, in: G.J.E. Rawlins (Ed.), *Foundations of Genetic Algorithms* (Morgan Kauffman, San Mateo, CA, 1991) 265–283.
- [20] L.J. Eshelman, J.D. Schaffer, Real-coded genetic algorithms and interval-schemata, in: *Foundations of Genetic Algorithms 2* (Morgan Kauffman, San Mateo, CA, 1993) 187–202.
- [21] J. Espinosa and J. Vandewalle, Constructing fuzzy models with linguistic integrity from numerical data-afreli algorithm, *IEEE Trans. Fuzzy Syst. - Part B: Cybernetics*, 8:5 (2000) 591–600.
- [22] P.Y. Glorennec, Application of fuzzy control for building energy management, in: *Building Simulation: International Building Performance Simulation Association 1* (Sophia Antipolis, France, 1991) 197–201.
- [23] A. F. Gómez-Skarmeta, F. Jiménez, Fuzzy modeling with hybrid systems, *Fuzzy Sets and Systems* 104 (1999) 199–208.
- [24] H. B. Gürocak, A genetic-algorithm-based method for tuning fuzzy logic controllers, *Fuzzy Sets and Systems*, 108:1 (1999) 39–47.
- [25] S. Halgamuge, M. Glesner, Neural networks in designing fuzzy systems for real world applications, *Fuzzy Sets and Systems* 65:1 (1994) 1–12.



- [26] F. Herrera, M. Lozano, J.L. Verdegay, Fuzzy connectives based crossover operators to model genetic algorithms population diversity, *Fuzzy Sets and Systems* 92:1 (1997) 21–30.
- [27] F. Herrera, M. Lozano, J.L. Verdegay, A learning process for fuzzy control rules using genetic algorithms, *Fuzzy Sets and Systems* 100 (1998) 143–158.
- [28] F. Herrera, M. Lozano, and J. L. Verdegay, Tuning fuzzy controllers by genetic algorithms, *Int. J. of Approximate Reasoning* 12 (1995) 299–315.
- [29] F. Herrera and L. Martínez, A 2-tuple fuzzy linguistic representation model for computing with words, *IEEE Trans. Fuzzy Syst.* 8 (2000) 746–752.
- [30] K. Hirota (Ed.), *Industrial applications of fuzzy technology* (Springer-Verlag, 1993).
- [31] S. Huang, R.M. Nelson, Rule development and adjustment strategies of a fuzzy logic controller for an HVAC system - Parts I and II (analysis and experiment), *ASHRAE Transactions* 100:1 (1994) 841–850, 851–856.
- [32] H. Ishibuchi, T. Murata, I. B. Türksen, Single-objective and two-objective genetic algorithms for selecting linguistic rules for pattern classification problems, *Fuzzy Sets and Systems* 89 (1997) 135–150.
- [33] H. Ishibuchi, K. Nozaki, N. Yamamoto, H. Tanaka, Selecting fuzzy if-then rules for classification problems using genetic algorithms, *IEEE Transactions on Fuzzy Systems* 9:3 (1995) 260–270.
- [34] Y. Jin, W. von Seelen, and B. Sendhoff, On generating *FLC*<sup>3</sup> fuzzy rule systems from data using evolution strategies, *IEEE Transactions on Systems, Man, and Cybernetics* 29:4 (1999) 829–845.
- [35] C.L. Karr, Genetic algorithms for fuzzy controllers, *AI Expert* 6:2 (1991) 26–33.
- [36] A. Krone, H. Krause, T. Slawinski, A new rule reduction method for finding interpretable and small rule bases in high dimensional search spaces, *Proceedings of the 9th IEEE International Conference on Fuzzy Systems*, San Antonio, TX, USA, 2000, 693–699.
- [37] L. Lu, W. Cai, L. Xie, S. Li, Y.C. Soh, HVAC system optimization in building section, *Energy and Buildings* 37 (2005) 11–22.
- [38] E.H. Mamdani, Applications of fuzzy algorithms for control a simple dynamic plant, *Proceedings of the IEEE* 121:12 (1974) 1585–1588.
- [39] E.H. Mamdani, S. Assilian, An experiment in linguistic synthesis with a fuzzy logic controller, *International Journal of Man-Machine Studies* 7 (1975) 1–13.

- [40] D. Nauck and R. Kruse, Neuro-fuzzy systems for function approximation, *Fuzzy Sets and Systems* 101:2 (1999) 261–271.
- [41] J. V. de Oliveira, Semantic constraints for membership function optimization, *IEEE Trans. Syst., Man, Cybern. - Part A: Systems and Humans*, 29:1 (1999) 128–138.
- [42] J. V. de Oliveira, Towards neuro-linguistic modeling: constraints for optimization of membership functions, *Fuzzy Sets and Systems* 106:3 (1999) 357–380.
- [43] J. Pargfrieder, H. JÖRGL, An integrated control system for optimizing the energy consumption and user comfort in buildings, *Proceedings of the 12th IEEE International Symposium on Computer Aided Control System Design (Glasgow, Scotland, 2002)* 127–132.
- [44] A. Rahmati, F. Rashidi, M. Rashidi, A hybrid fuzzy logic and PID controller for control of nonlinear HVAC systems, *Proceedings of the IEEE International Conference on Systems, Man and Cybernetics 3 (Washington, D.C., USA, 2003)* 2249–2254.
- [45] H. Roubos, M. Setnes, Compact fuzzy models through complexity reduction and evolutionary optimization, *Proceedings of the 9th IEEE International Conference on Fuzzy Systems 2 (San Antonio, Texas, USA, 2000)* 762–767.
- [46] H. Roubos and M. Setnes, Compact and transparent fuzzy models through iterative complexity reduction, *IEEE Trans. on Fuzzy Systems* 9:4 (2001) 515–524, .
- [47] R. Rovatti, R. Guerrieri, G. Bacarani, Fuzzy rules optimization and logic synthesis, *Proceedings of the 2nd IEEE International Conference on Fuzzy Systems 2 (San Francisco, USA, 1993)* 1247–1252.
- [48] M. Setnes, R. Babuska, U. Kaymak, H. R. van Nauta-Lemke, Similarity measures in fuzzy rule base simplification, *IEEE Transactions on Systems, Man, and Cybernetics—Part B: Cybernetics* 28 (1998) 376–386.
- [49] M. Setnes, H. Hellendoorn, Orthogonal transforms of ordering and reduction of fuzzy rules, *Proceedings of the 9th IEEE International Conference on Fuzzy Systems 2 (San Antonio, Texas, USA, 2000)* 700–705.
- [50] D. Whitley, J. Kauth, GENITOR: A different genetic algorithm, *Proceedings of the Rocky Mountain Conference on Artificial Intelligence, Denver (1988)* 118–130.
- [51] J. Wu, W. Cai, Development of an adaptive neuro-fuzzy method for supply air pressure control in HVAC system, *Proceedings of the IEEE International Conference on Systems, Man and Cybernetics 5 (Nashville, Tennessee, USA, 2000)* 3806–3809.

- [52] I.H. Yang, M.S. Yeo, K.W. Kim, Application of artificial neural network to predict the optimal start time for heating system in building, *Energy Conversion and Management* 44 (2003) 2791–2809.
- [53] J. Yen, L. Wang, Simplifying fuzzy rule-based models using orthogonal transformation methods, *IEEE Transactions on Systems, Man, and Cybernetics—Part B: Cybernetics* 29 (1999) 13–24.